

Precipitation Transmitter

Instruction for Use

5.4033.35.xxx / 5.4033.36.xxx



Dok. No. 021326/08/22

THE WORLD OF WEATHER DATA

Safety Instructions

- Before operating with or at the device/product, read through the operating instructions. This manual contains instructions which should be followed on mounting, start-up, and operation. A non-observance might cause:
 - failure of important functions
 - Endangering of persons by electrical or mechanical effect
 - Damage to objects
- Mounting, electrical connection and wiring of the device/product must be carried out only by a qualified technician who is familiar with and observes the engineering regulations, provisions and standards applicable in each case.
- Repairs and maintenance may only be carried out by trained staff or **Adolf Thies GmbH & Co. KG**. Only components and spare parts supplied and/or recommended by **Adolf Thies GmbH & Co. KG** should be used for repairs.
- Electrical devices/products must be mounted and wired only in voltage-free state.
- **Adolf Thies GmbH & Co KG** guarantees proper functioning of the device/products provided that no modifications have been made to the mechanics, electronics or software, and that the following points are observed:
- All information, warnings and instructions for use included in these operating instructions must be taken into account and observed as this is essential to ensure trouble-free operation and a safe condition of the measuring system / device / product.
- The device / product is designed for a specific application as described in these operating instructions.
- The device / product should be operated with the accessories and consumables supplied and/or recommended by **Adolf Thies GmbH & Co KG** .
- Recommendation: As it is possible that each measuring system / device / product under certain conditions, and in rare cases, may also output erroneous measuring values, it is recommended using redundant systems with plausibility checks with **security-relevant applications**.

Environment

- As a longstanding manufacturer of sensors Adolf Thies GmbH & Co KG is committed to the objectives of environmental protection and is therefore willing to take back all supplied products governed by the provisions of "ElektroG" (German Electrical and Electronic Equipment Act) and to perform environmentally compatible disposal and recycling. We are prepared to take back all Thies products concerned free of charge if returned to Thies by our customers carriage-paid.
- Make sure you retain packaging for storage or transport of products. Should packaging however no longer be required, arrange for recycling as the packaging materials are designed to be recycled.



Documentation

- © Copyright **Adolf Thies GmbH & Co KG**, Göttingen / Germany
- Although this operating instruction has been drawn up with due care, **Adolf Thies GmbH & Co KG** can accept no liability whatsoever for any technical and typographical errors or omissions in this document that might remain.
- We can accept no liability whatsoever for any losses arising from the information contained in this document.
- Subject to modification in terms of content.
- The device / product should not be passed on without the/these operating instructions.

Contents

1	Models Available.....	4
2	Application	4
3	Mode of Operation	4
4	Description Electrical Output.....	5
4.1	Output 1: Analogue Output	5
4.1.1	Signal Processing	5
4.2	Output 2: Pulse Output	7
5	Recommendation Site Selection / Standard Installation	7
6	Installation.....	7
6.1	Mechanical Mounting.....	8
6.2	Electrical Mounting	11
6.2.1	Plug mounting.....	11
6.3	Connecting Diagram.....	12
7	Setting the Signal Processing, Measuring Range, and gliding Period	12
8	Maintenance	14
8.1	Cleansing Procedure	15
8.2	Check of the Tipping Bucket.....	15
9	Technical Data.....	16
10	Dimensional Drawing.....	17
11	Accessories (available optional).....	18
12	EC-Declaration of Conformity	19

Figures

Figure 1:	accumulating precipitation sum	6
Figure 2:	gliding precipitation sum	6
Figure 3:	DIP- switch	13

Tables

Table 1:	Models available.....	4
Table 2:	Updating	6
Table 3:	set from DIP- switch.....	13

1 Models Available

Order-No.	Heating	Supply	Analogue - Output	Meas. range
5.4033.35.040	yes	24V AC/DC	0 ... 20mA (max. 500 ohm)	0 ... 10mm * 0 ... 20mm 0 ... 25mm 0 ... 50mm selectable via DIP-switch
5.4033.35.041	yes	24V AC/DC	4 ... 20mA (max. 500 ohm)	
5.4033.35.061	yes	24V AC/DC	0 ... 10V	
5.4033.35.073	yes	24V AC/DC	0 ... 5V	
5.4033.36.040	no	10 ... 24V DC	0 ... 20mA (load 150 .. 500 ohm)	
5.4033.36.041	no	10 ... 24V DC	4 ... 20mA (load 150 .. 500 ohm)	
5.4033.36.061	no	13 ... 24V DC	0 ... 10V	
5.4033.36.073	no	13 ... 24V DC	0 ... 5V	

* Factory adjustment

Table 1: Models available

2 Application

The instrument is designed to measure the height, quantity and the intensity of the precipitation striking the surface of the earth. The measuring principle, tipping bucket, is basing on the description „Guide to Meteorological Instruments No 8“ of the WMO (World Meteorological Organization).

3 Mode of Operation

The precipitation, collected by the collecting surface and the collecting funnel, is conducted into a tipping-bucket. The tipping bucket consists of two bucket-compartments. Is one of these compartments filled with water it tips over, and the water drains off. Meanwhile subsequent rain falls into the newly positioned upper compartment. The tipping movement is detected by Hall-Sensors, and a connected electronics, and produces a respective output signal.

There are two outputs available:

Output 1: Analogue output for the output of the precipitation sum as voltage- or current value.

Output 2 :Pulse output for the output of single precipitation meter pulse .

The electronics of the precipitation transmitter is equipped with a linearising system. The linearising procedure is basing on a intensity-dependent pulse number correction for the range from approx. 0,5 ... 11mm/min.

Each instrument is calibrated with a water quantity of 200cm³ (= 10mm precipitation height).

- Precipitation transmitters with built-in heating (5.4033.35.xxx) liquefy snow and hail and consequently, are suitable for winter use.
- All parts are corrosion-resistant. The casing consists of stainless steel (V2A).

For Information:

A precipitation height of 1mm corresponds to a water volume of 1 litre on 1m² ground area.

4 Description Electrical Output

4.1 Output 1: Analogue Output

The measured precipitation value is available at the analogue output in the form of electrical output signals (see chapter 1). In case of a DC-supply, the analogue output refers to supply ground (-).

4.1.1 Signal Processing

For the signal processing please select as follows:

1. Accumulating Precipitation Sum (= the sum of all precipitation events up to a maximum measuring range)

With this procedure the precipitation events are added up to a maximum value (see measuring range), and are output as analogue value. With every precipitation event the analogue value is updated. In case of exceeding the maximum value the analogue value is automatically reset. In parallel to this, an external signal (RESET) can reset the analogue value at any time (see figure 1).

Application example for accumulating precipitation sum:
- for recording the precipitation on recording instruments.

2. Gliding Precipitation Sum (= the sum of precipitation events over a past period)

With this procedure (see figure 2) the precipitation events are added in a circular buffer over a selectable *gliding time period*. The updating (see table 2) of the analogue value is carried out continuously within the scope of the selected past period. After starting the precipitation transmitter the analogue value is in the set-up for the selected period. After the set-up delay the analogue value represents the gliding sum value of the precipitation (see figure 2)

The measuring range to be selected has to come up to the expected precipitation quantities, as an internal measuring range overflow leads to erroneous gliding sum values.

Note:

In this case, the sensor outputs values greater than the specified maximum value, e.g. 20.7mA).

Application example for gliding precipitation sum:

- for visualising the precipitation on display- or recording instruments.
- for controlling certain processes, for example with sewage treatment plants.

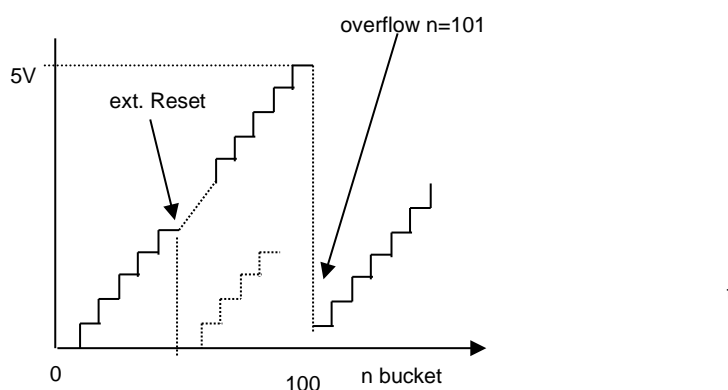

Figure 1: accumulating precipitation sum

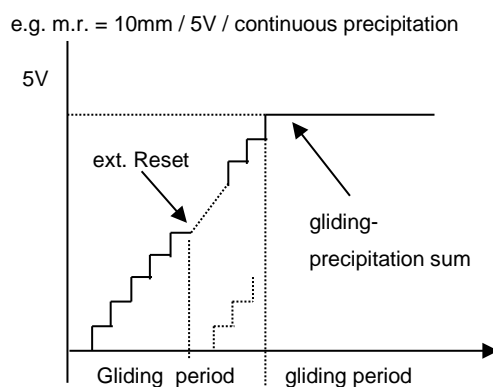

Figure 2: gliding precipitation sum

Updating Time	With gliding Period
every 25 sec.	10 Min.
every 150 sec.	60 Min.
every 15 min.	6 h.
every hour	24 h.

Table 2: Updating

4.2 Output 2: Pulse Output

In parallel to the analogue signal output the precipitation pulse (1 pulse = 0,1mm precipitation) is available via an opto-coupler.

5 Recommendation Site Selection / Standard Installation

Depending on the wind velocity, a certain amount of the precipitation particles are blown away over the deposit area. Therefore, an installation in a completely open area as well as at the direct lee-side of an object is to be avoided. Gardens e.g., where hedgerows or similar objects offer protection against the wind, are more suitable.

The World Meteorological Organization recommends that precipitation gauges be installed at a distance which is at least four times as high as the next higher object. If this is not possible, it is to be observed that an elevation angle of $\leq 45^\circ$ towards the surrounding plants, buildings etc. is adhered to.

The precipitation gauge is to be installed in such a way that the collection area is horizontal and is situated 1m above ground. If snowfall is to be expected regularly within the area of the measuring instrument this distance should be increased respectively.

Attention:

Precipitation gauges are to be installed in a way that ensures a vibrationless operation.

6 Installation

Attention:

- ***The electrical connection is to be carried out by experts only.***
- ***Please open the instrument only with dry ambient conditions.***
- ***Do not damage the exposed electronics!***

6.1 Mechanical Mounting

Attention:

- *The included tipping bucket must be operated only with this precipitation transmitter.*
- *Please don't touch the inner surfaces of the tipping bucket.*
- *The drain pins of the tipping bucket must not be deformed.*

Remark:

The combination filter/cram (14/15) in the collecting funnel is to be removed in winter operation with snowfall.

Tools Required:

- Wrench, wrench width 13
- Allen wrench, wrench width 3

Installation is carried out as follows (see also Figure 1)

1. Remove the precipitation transmitter from the box.
2. Remove the small box from the collecting funnel of the housing **(1)**.
Unpack tipping bucket **(7)** and filter **(12)** and put them aside.

Important:

The tipping bucket is allocated to the precipitation transmitter.
Tipping bucket and precipitation transmitter are marked each by the same tipping bucket number.

The tipping bucket number is located as small label

- on the small box.
- on the pan
- on the base

3. Remove the bag from the collecting funnel of the housing **(1)**,
remove the combination filter/cram **(14/15)** and put it aside.
4. Put the precipitation transmitter on a suitable base, and fix it by means of the screws **(4)** inside the base **(3)**.
5. Loosen two screws **(2)** at the housing **(1)** and lift the housing carefully up.
6. Please check, if the level- indicator **(5)** on the ground plate indicates a horizontal mounting, if necessary, correct it by the screws **(4)** inside the base **(3)**.
7. Push the collector **(13)** upward by loosening the knurled screw **(11)** and fix it.

8. Then insert the tipping bucket **(7)** carefully into the bearing cup of the pan **(6)**.

Important:

- The magnet **(10)** of the tipping bucket must indicate towards the pc-board.
- Please check once again if the tipping bucket, and the precipitation transmitter have the right allocation (synchronize numbers).

9. Afterwards, test the tipping bucket manually on trouble-free tipping.

10. Insert the filter **(12)**, which was put aside, into the collector **(13)**.

11. Put the collector back into lower position, and fix it.

12. Put the housing carefully back on the instrument, and fix it by means of the two instrument screws.

13. Insert the combination filter/cram **(14/15)**, which was put aside, into the passage of the collecting funnel.

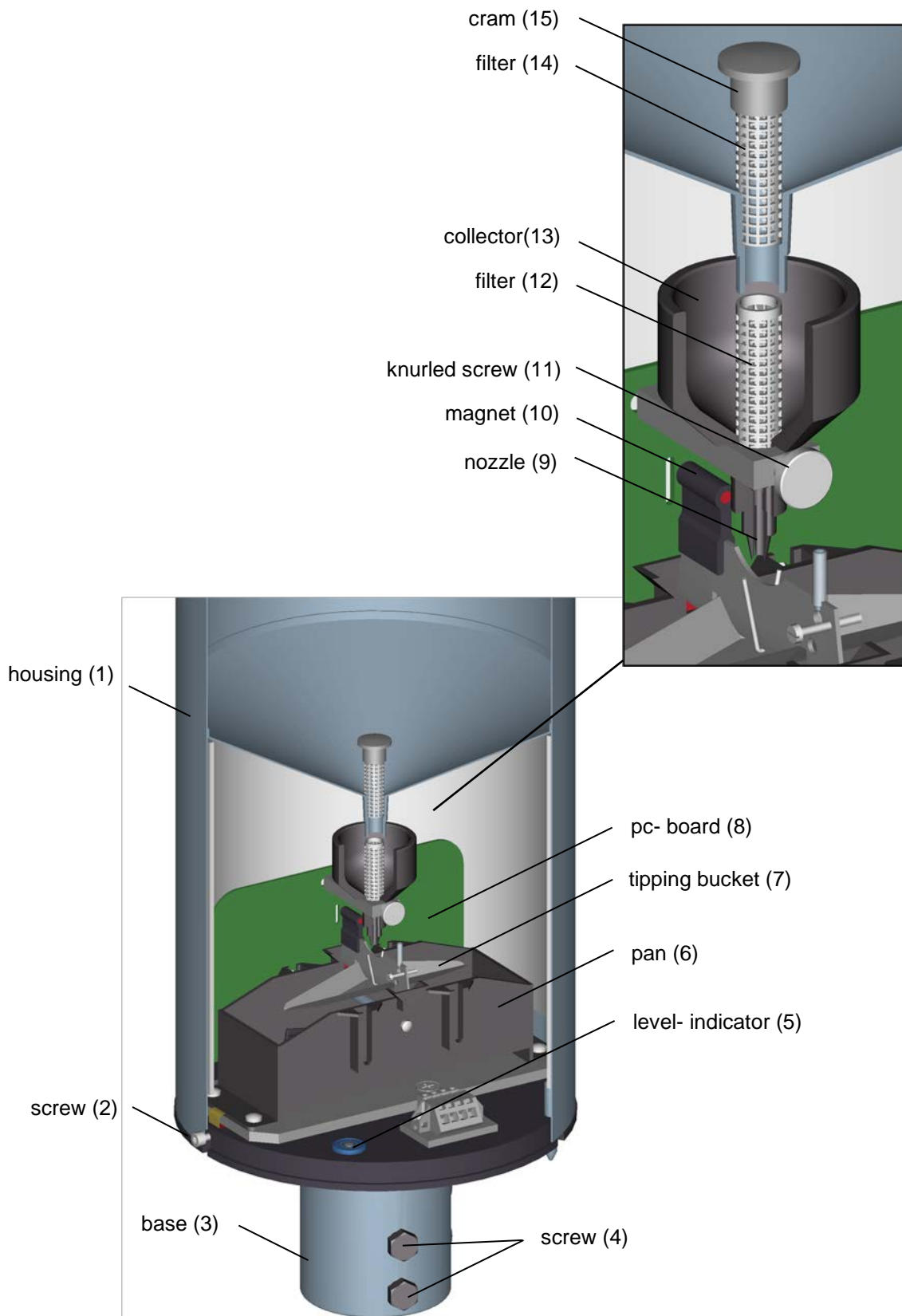

6.2 Electrical Mounting

- Please solder a cable (for ex.. LiYCY 0,5mm²) to the attached connecting plug acc. to the respective connecting diagram (see also chapter 9).
- Plug-mounting see chapter 6.

Remark:

Connections 6 and 7 are not used by the connecting plug at the model with-out heating.

6.2.1 Plug mounting

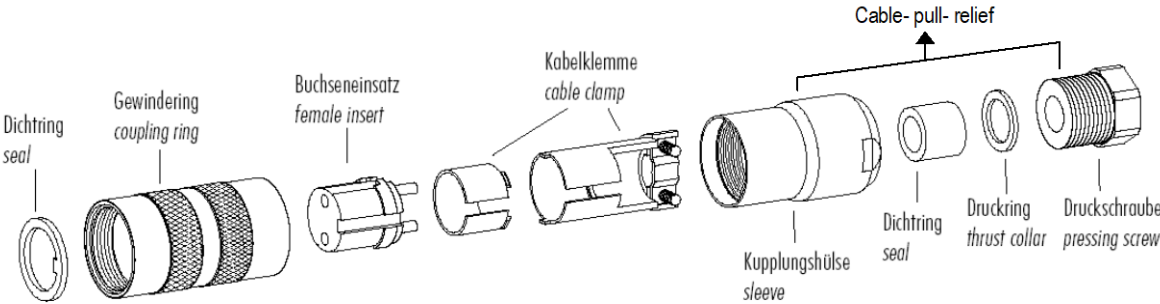
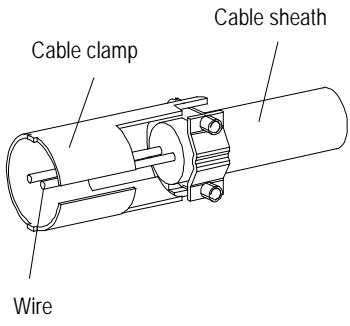
<p>Coupling socket, Typ:Binder, Serial 423, EMC with cable clamp Cable connection: without cable shield</p>	
	
<ol style="list-style-type: none"> 1. Stringing parts on cable acc. to plan given above. 2. Stripping cable sheath 20mm. 3. Cutting uncovered shield 20mm. 4. Stripping wire 5mm. 5. Soldering wire to the insert. 6. Positioning shield in cable clamp. 7. Screwing-on cable clamp. 8. Assembling remaining parts acc. to upper plan. 9. Tightening pull-relief of cable by screw-wrench (SW16 und 17). 	

6.3 Connecting Diagram

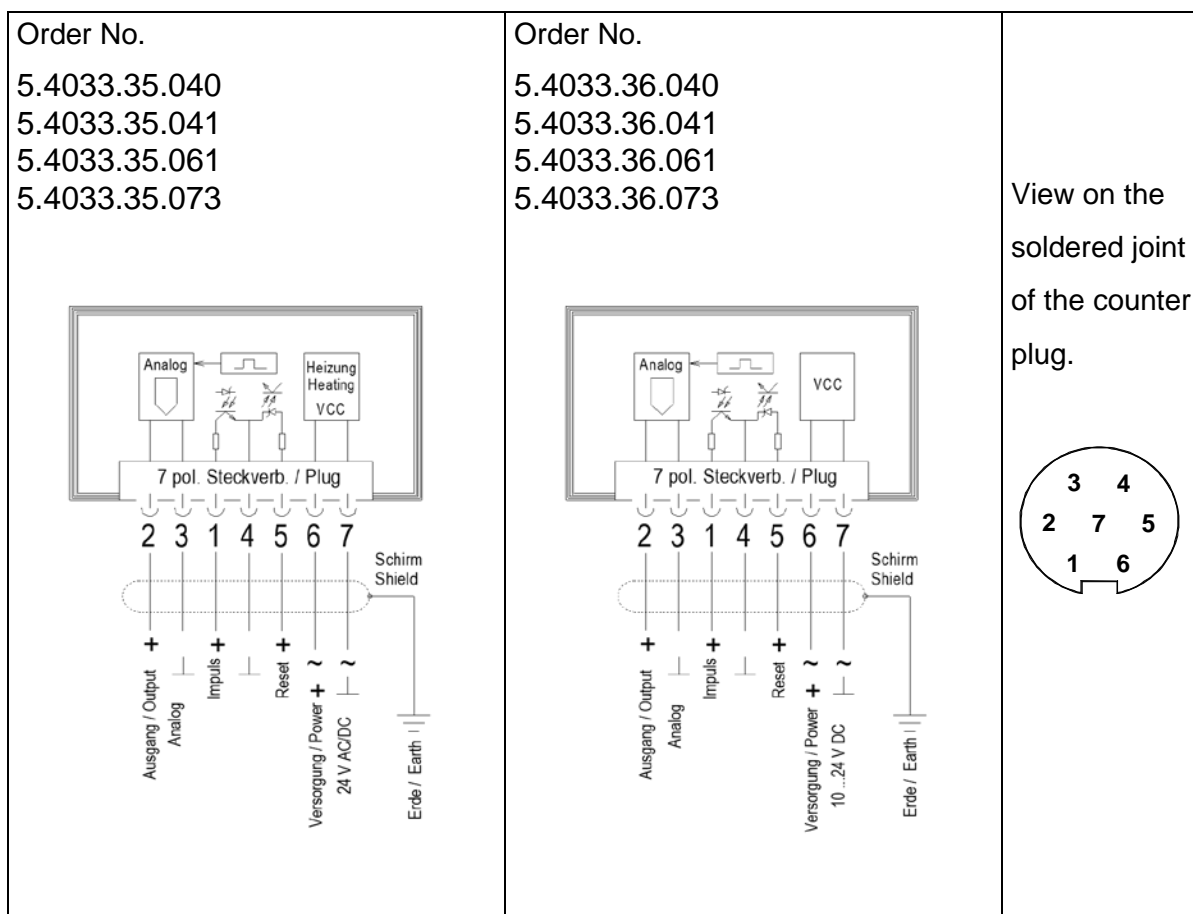

7 Setting the Signal Processing, Measuring Range, and gliding Period

(only necessary in case the factory adjustment is to be changed)

On the pc-board there is a 6-pole DIP-switch for setting the requested signal processing, measuring range, and period. For this, please put the single switches into the right position, acc. to the table. In the factory, the instrument is pre-set for the function „accumulating precipitation sum“ and the measuring range 0...10mm.

Remark:

After the DIP-switch has been set, disconnect briefly the supply voltage, so that the precipitation sensor can accept the new information.

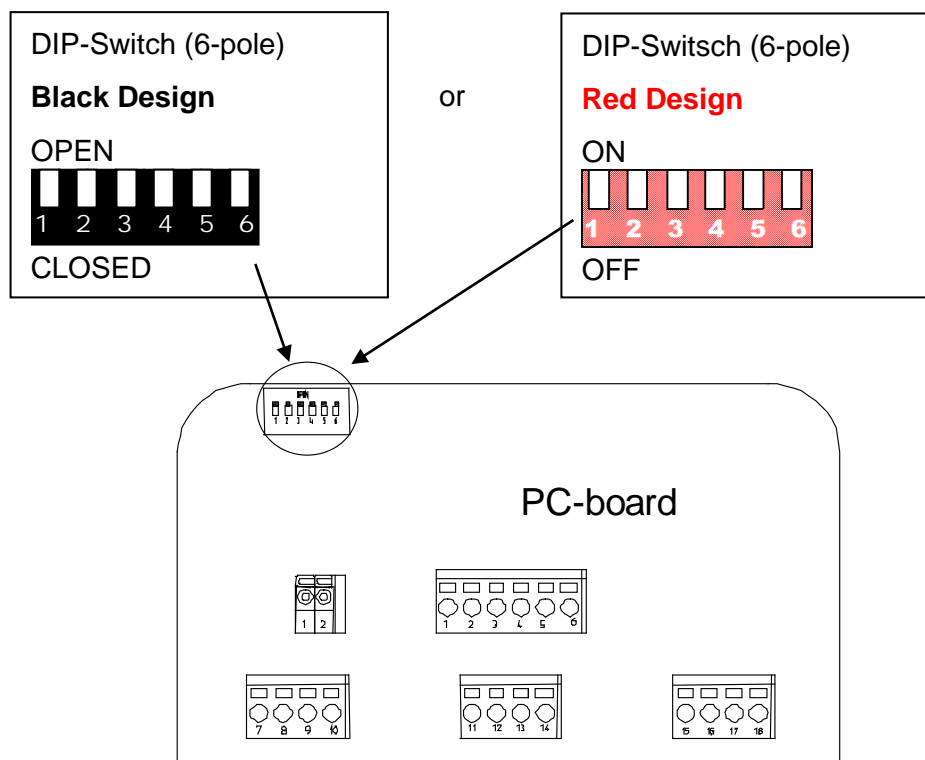

Figure 3: DIP- switch

	DIP-Switch, black design		DIP-Switch, red design	
Measuring Range	DIP-switch 1	DIP-switch 2	DIP-switch 1	DIP-switch 2
10 mm *	CLOSED	CLOSED	ON	ON
20 mm	OPEN	CLOSED	OFF	ON
25 mm	CLOSED	OPEN	ON	OFF
50 mm	OPEN	OPEN	OFF	OFF
Gliding Period	DIP-switch 3	DIP-switch 4	DIP-switch 3	DIP-switch
10 min	CLOSED	CLOSED	ON	ON
60 min	OPEN	CLOSED	OFF	ON
6 h	CLOSED	OPEN	ON	OFF
24 h	OPEN	OPEN	OFF	OFF
Signal Processing	DIP-switch 5		DIP-switch 5	
Accumulating precipitation sum *	CLOSED		ON	
Gliding precipitation sum	OPEN		OFF	
Offset-Function	DIP-switch 6		DIP-switch 6	
0-20mA / 0-10V / 0-5V	CLOSED		ON	
4-20mA / 2-10V / 1-5V	OPEN		OFF	

Table 3: set from DIP- switch

= factory adjustment

8 Maintenance

Attention:

The electrical connection is to be carried out by experts only.

Please open the instrument only with dry ambient conditions.

Do not damage the exposed electronics!

Attention:

- Do not use any benzene, alcohol, or other cleansing agents.

- Never treat the inner surfaces of the tipping bucket with emery paper or something similar.

- Do not touch the inner surfaces with hands.

- Please take care that the draining pins are not deformed.

The instrument is designed in such a way that all of the parts requiring maintenance are easily accessible once the case has been removed.

The most important factors for precise measurements are a free and undisturbed inflow, and clean, grease-free inner surfaces of the tipping bucket.

The tipping bucket is made of zinc-plate, the surface of which is specifically oxidised, in order to achieve a hygrophilic surface. It guarantees an accurate draining behaviour of the measuring liquid, and must not be removed mechanically.

The maintenance interval should depend on the degree of pollution of the instrument. It is advisable to make a visual inspection at short intervals as particles falling from above, such as foliage, bird dropping etc. can affect the measurement.

8.1 Cleansing Procedure

Tools Required:

- a clean cloth
- a small bottle brush
- a soft brush
- possibly gentle soap

Cleansing is carried out as follows: (s.a. Figure 1: Instrument construction):

1. Switch off supply voltage of heating.
2. Remove the filter **(14)** upward from the collecting funnel of the housing **(1)** and clean it.
3. Loosen the two screws **(2)** at the housing, remove housing and clean it.
4. Remove filter **(12)** from the collector **(13)** and clean it.
5. The collector **(13)** with the **nozzle (9)** can be removed after unscrewing the knurled **screw (11)**. Clean the nozzle boring by means of small bottle brush.
6. Remove the **tipping bucket (7)** carefully from the pan **(6)**.
7. Clean the inner surfaces with clear water, if heavily soiled (grease) also with gentle soap water. For this, please use a soft brush.
8. In case of heavy pollution please clean also the pan **(6)**.
9. After cleansing, please re-insert the parts in reversed order.

8.2 Check of the Tipping Bucket

For checking the measuring instrument it is advisable to pour a certain amount of precipitation slowly and steadily into the collecting funnel. That means, that for example a quantity of 200cm² induces a pulse number of 100.

The quantity of 200cm² should be filled in constantly over a period of approx. 10 minutes.

For Information:

Approx. 98% of the precipitation in Germany are falling with an intensity of 2mm/min.

Remark:

Every precipitation transmitter is checked, adjusted and calibrated at the manufacturers. If, in the course of time, the adjustment of the tipping bucket has changed as a result of external influences, we suggest a check and calibration in our factory.

9 Technical Data

Description	MIN	TYPE	Max	Unit
General				
Collecting surface		200		cm ²
Volume of tipping bucket		2		cm ³
Measuring range	0		11	mm/min
Resolution		0,1		mm NS
Accuracy (within the range of 0.. 11 mm/min)			± 3 *	%
Ambient temperature (w/o heating)	0		60	°C
Ambient temperature (with heating)	- 25		60	°C
Mounting on stand pipe (1 ½")			50	Ømm
Weight			3,3	kg
Electrical Output				
Output 1: Analogue				
Resolution of analogue value		960		steps
Accuracy of analogue value		± 1		% of m.r
Linearity error			± 0.1	%
Load (Vcc ≥ 17V)			500	ohm
Load (Vcc ≥ 10V)	150			ohm
I _{max} (voltage output 0..10V) Vcc ≥ 13V	1			mA
I _{max} (voltage output 0..10V) Vcc ≥ 17V		20		mA
Output 2: Digital (opto-coupler)				
Pulse length		125		ms
Pulse pause	125			ms
Tipping bucket frequency	0		2	Hz
Supply voltage			24	V DC
Pulse current	8	16		mA
R _v (pre-resistance in the precip. transmitter) (fig.)		100		Ω
Reset-input (opto-coupler)				
Pulse length	70			ms
Pulse current	1		40	mA
R _v (pre-resistance in the precip. transmitter) (fig.)		6200		ohm
Supply voltage				
V _{cc} (with heating)		24	28	V (AC/DC)
V _{cc} (w/o heating)	10		24	V (DC)
I _{cc} (w/o heating) (at voltage output)			3	mA

Heating				
Heating power (at 24V supply)		48,5		W
heating – switch-on temperature		5		°C
Heating - hysteresis		2		°C

* The accuracies were determined under laboratory conditions

Test medium: distilled water.

Test volume: 200cm³ = 10mm precipitation = 100 tipping bucket pulse
 10mm precipitation per minute corresponds to a quantity of 600 litre per hour.

(General: A precipitation height of 1mm corresponds to a water volume of 1 litre on 1m² ground area)

10 Dimensional Drawing

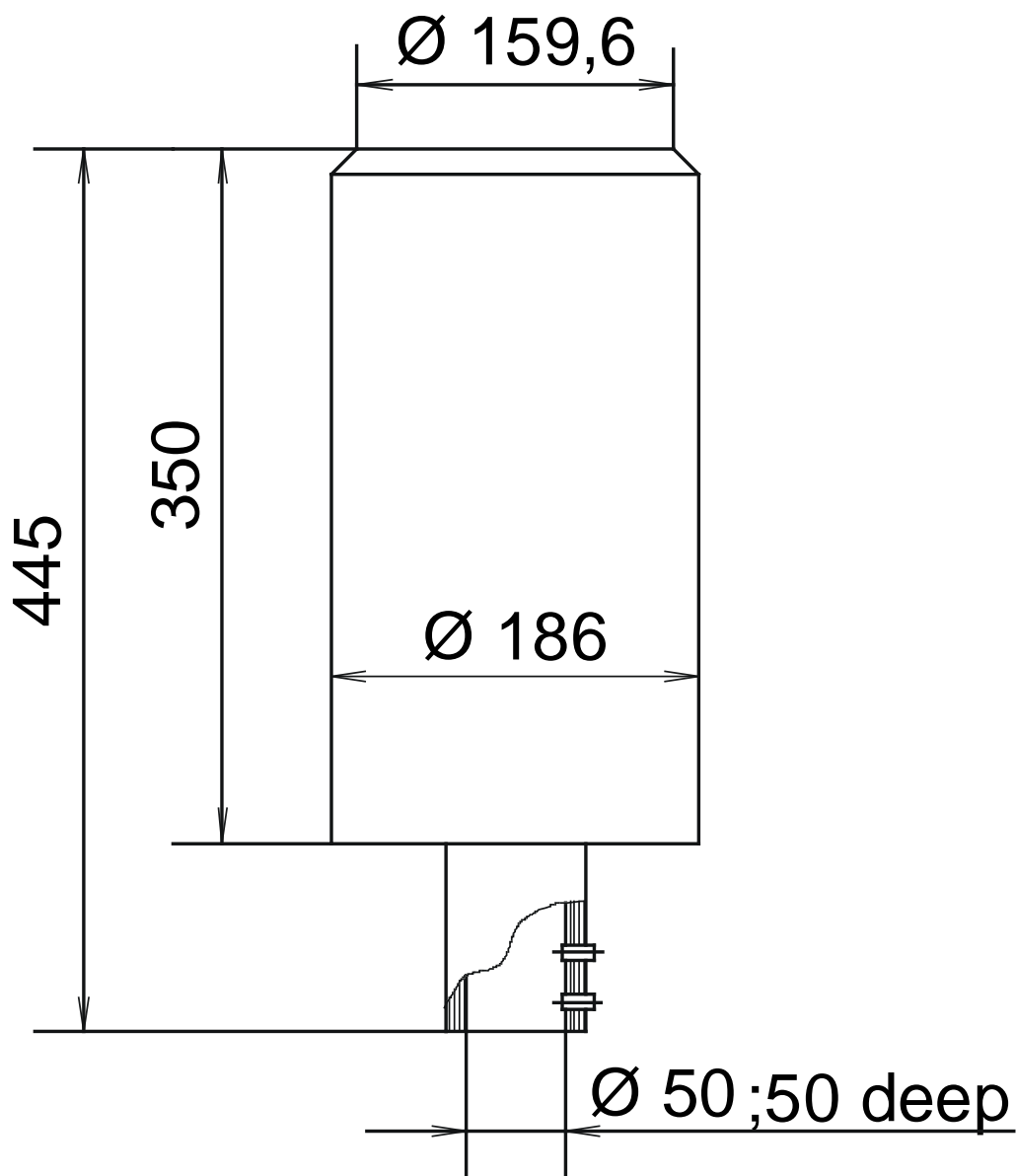

11 Accessories (available optional)

Stand	9.4031.35.065	Serves for mounting the precipitation transmitter. The distance from the ground to the collecting surface is about 1,0 meter. Stands are available also for other distances.
Bird protection device	5.4010.00.010	Avoids birds sitting on the precipitation transmitter.
Power Supply Unit	9.3388.00.000	Serves for current supply of precipitation transmitter heating. Primary: 230V / 50Hz Secondary: 26V / 3,46A

12 EC-Declaration of Conformity

Manufacturer: Adolf Thies GmbH & Co. KG
 Hauptstraße 76
 37083 Göttingen, Germany
<http://www.thiesclima.com>

Product: Precipitation Transmitter

Doc. Nr. 901-44788_CE

Article Overview:

5.4032.35.006	5.4032.35.007	5.4032.35.008	5.4032.35.009	5.4032.35.010	5.4032.35.011	5.4032.35.020	5.4032.35.028	5.4032.35.107	5.4032.35.108
5.4032.35.228	5.4032.35.608	5.4032.35.909	5.4032.45.008	5.4032.45.009	5.4033.35.040	5.4033.35.041	5.4033.35.061	5.4033.35.073	5.4033.36.040
5.4033.36.041	5.4033.36.061	5.4033.36.073							

The indicated products correspond to the essential requirement of the following European Directives and Regulations:

2014/30/EU	26.02.2014	DIRECTIVE 2014/30/EU OF THE EUROPEAN PARLIAMENT AND OF THE COUNCIL of 26 February 2014 on the harmonisation of the laws of the Member States relating to electromagnetic compatibility.
2017/2102/EU	15.11.2017	DIRECTIVE (EU) 2017/2102 of the European Parliament and of the Council of November 15, 2017 amending Directive 2011/65 / EU on the restriction of the use of certain hazardous substances in electrical and electronic equipment.
2012/19/EU	13.08.2012	DIRECTIVE 2012/19/EU OF THE EUROPEAN PARLIAMENT AND OF THE COUNCIL of 4 July 2012 on waste electrical and electronic equipment (WEEE).
2014/90/EU	23.07.2014	DIRECTIVE 2014/90 / EU of the European Parliament and of the Council of 23 July 2014 on marine equipment and repealing Council Directive 96/98 / EC Text with EEA relevance.
2018/1139/EU	04.07.2018	Regulation (EU) 2018/1139 of the European Parliament and of the Council of 4 July 2018 on common rules in the field of civil aviation and establishing a European Union Aviation Safety Agency.

The indicated products comply with the regulations of the directives. This is proved by the compliance with the following standards:

DIN EN 61000-6-2	2019-11	Electromagnetic compatibility Immunity for industrial environment
DIN EN 61000-6-3:2007 + A1:2011	2011-09	Electromagnetic compatibility (EMC). Generic standards. Emission standard for residential, commercial and light-industrial environments
DIN EN 61010-1	2020-03	Safety requirements for electrical equipment for measurement, control, and laboratory use. General requirements
DIN EN 63000	2019-05	Technical documentation for the assessment of electrical and electronic products with respect to the restriction of hazardous substances.

Legally binding signature:



General Manager - Dr. Christoph Peper

Legally binding signature:



Development Manager - ppa. Jörg Peterleit

This declaration certifies the compliance with the mentioned directives, however does not include any warranty of characteristics.

Please pay attention to the security advises of the provided instructions for use.

13 UK-CA-Declaration of Conformity

Manufacturer: Adolf Thies GmbH & Co. KG
 Hauptstraße 76
 37083 Göttingen, Germany
<http://www.thiesclima.com>

Product: Precipitation Transmitter

Doc. Nr. 901-44788_CA

Article Overview:

5.4032.35.006	5.4032.35.007	5.4032.35.008	5.4032.35.009	5.4032.35.010	5.4032.35.011	5.4032.35.020	5.4032.35.028	5.4032.35.107	5.4032.35.108
5.4032.35.228	5.4032.35.608	5.4032.35.909	5.4032.45.008	5.4032.45.009	5.4033.35.040	5.4033.35.041	5.4033.35.061	5.4033.35.073	5.4033.36.040
5.4033.36.041	5.4033.36.061	5.4033.36.073							

The indicated products correspond to the essential requirement of the following Directives and Regulations:

1091	08.12.2016	The Electromagnetic Compatibility Regulations 2016
RoHS Regulations 2012	01.01.2021	The Restriction of the Use of Certain Hazardous Substances in Electrical and Electronic Equipment Regulations 2012
3113	01.01.2021	Regulations: waste electrical and electronic equipment (WEEE)
2014/90/EU	23.07.2014	DIRECTIVE 2014/90 / EU of the European Parliament and of the Council of 23 July 2014 on marine equipment and repealing Council Directive 96/98 / EC Text with EEA relevance.
2018/1139/EU	04.07.2018	Regulation (EU) 2018/1139 of the European Parliament and of the Council of 4 July 2018 on common rules in the field of civil aviation and establishing a European Union Aviation Safety Agency.

The indicated products comply with the regulations of the directives. This is proved by the compliance with the following standards:

BS EN IEC 61000-6-2	25.02.2019	Electromagnetic compatibility (EMC). Generic standards. Immunity standard for industrial environments
BS EN IEC 61000-6-3	30.03.2021	Electromagnetic compatibility (EMC). Generic standards. Emission standard for equipment in residential environments
BS EN 61010-1+A1	31.03.2017	Safety requirements for electrical equipment for measurement, control, and laboratory use. General requirements
BS EN IEC 63000	10.12.2018	Technical documentation for the assessment of electrical and electronic products with respect to the restriction of hazardous substances

This declaration of conformity is issued under the sole responsibility of the manufacturer.

Legally binding signature:



General Manager - Dr. Christoph Peper

Legally binding signature:



Development Manager - ppa. Jörg Petereit

This declaration certifies the compliance with the mentioned directives, however does not include any warranty of characteristics.

Please pay attention to the security advises of the provided instructions for use.

**Please contact us for your system requirements.
We advise you gladly.**

ADOLF THIES GMBH & CO. KG

Meteorology and environmental metrology
Hauptstraße 76 · 37083 Göttingen · Germany
Phone +49 551 79001-0 · Fax +49 551 79001-65
info@thiesclima.com

www.thiesclima.com

