

# Weather Station Compact Advanced (WSCA)

## Instruction for Use

4.906x.xx.00x

from software version 03/2026

MC firmware version 5.42

WLAN firmware version 1.90



Doc. No. 022084/03/26

THEWORLD OF WEATHER DATA

### Safety Instructions

- Before operating with or at the device/product, read through the operating instructions. This manual contains instructions which should be followed on mounting, start-up, and operation. A non-observance might cause:
  - failure of important functions
  - endangerment of persons by electrical or mechanical effect
  - damage to objects
- Mounting, electrical connection and wiring of the device/product must be carried out only by a qualified technician who is familiar with and observes the engineering regulations, provisions and standards applicable in each case.
- Repairs and maintenance may only be carried out by trained staff or **Adolf Thies GmbH & Co. KG**. Only components and spare parts supplied and/or recommended by **Adolf Thies GmbH & Co. KG** should be used for repairs.
- Electrical devices/products must be mounted and wired only in a voltage-free state.
- **Adolf Thies GmbH & Co KG** guarantees proper functioning of the device/products provided that no modifications have been made to the mechanics, electronics or software, and that the following points are observed:
  - All information, warnings and instructions for use included in these operating instructions must be taken into account and observed as this is essential to ensure trouble-free operation and a safe condition of the measuring system / device / product.
  - The device / product is designed for a specific application as described in these operating instructions.
  - The device / product should be operated with the accessories and consumables supplied and/or recommended by **Adolf Thies GmbH & Co KG** .
  - Recommendation: As it is possible that each measuring system / device / product may, under certain conditions, and in rare cases, may also output erroneous measuring values, it is recommended using redundant systems with plausibility checks for **security-relevant applications**.

### Environment

- As a longstanding manufacturer of sensors Adolf Thies GmbH & Co KG is committed to the objectives of environmental protection and is therefore willing to take back all supplied products governed by the provisions of "ElektroG" (German Electrical and Electronic Equipment Act) and to perform environmentally compatible disposal and recycling. We are prepared to take back all Thies products concerned free of charge if returned to Thies by our customers carriage-paid.
- Make sure you retain packaging for storage or transport of products. Should packaging however no longer be required, please arrange for recycling as the packaging materials are designed to be recycled.



### Documentation

- © Copyright **Adolf Thies GmbH & Co KG**, Göttingen / Germany
- Although these operating instructions have been drawn up with due care, **Adolf Thies GmbH & Co KG** can accept no liability whatsoever for any technical and typographical errors or omissions in this document that might remain.
- We can accept no liability whatsoever for any losses arising from the information contained in this document.
- Subject to modification in terms of content.
- The device / product should not be passed on without the/these operating instructions.

## Table of contents

1	Device versions .....	6
2	Application .....	7
3	Structure and mode of operation .....	8
4	Installation and choice of location .....	12
4.1	Choice of installation location .....	12
4.2	Mechanical assembly .....	13
4.2.1	North orientation .....	14
4.3	Electrical installation .....	14
4.3.1	Cables .....	14
4.3.2	Wiring diagram .....	16
4.3.3	Connection for 5-core cable Article no. 510023 / 510024 / 510197 .....	16
5	Commissioning MQTT / LoRaWAN .....	17
6	WLAN .....	17
6.1	Function of the WLAN module .....	17
6.2	Commissioning the WSCA via WLAN .....	18
6.3	Commissioning with the Thies Cumulus app .....	18
6.4	Connect with another MQTT broker .....	26
6.4.1	Data on the MQTT broker .....	28
6.5	Integrate WSCA into your own group .....	29
6.6	MODBUS TCP .....	33
7	LoRaWAN - Low Power Wide Area Network .....	34
7.1	Communication in APB Mode .....	34
7.2	Communication in OTAA mode .....	35
	There are two options for commissioning the WSCA with .....	35
	LoRaWAN: .....	35
7.3	Commissioning with the Thies Cumulus app .....	35
7.4	Configuring the WSCA via serial interface .....	42
7.4.1	LoRa end device activation .....	42
7.4.2	Data transmission with LoRaWAN .....	42
7.4.3	Checking the data transmission .....	46
7.4.4	Error detection .....	46
7.4.5	Error code for LoRaWAN communication .....	47
8	Maintenance .....	48
9	Forecast data .....	49
9.1	Forecast data in the MODBUS data set .....	49
9.2	Forecast data in the THIES command interpreter .....	50
10	Interface .....	50
10.1	Command interpreter THIES (4.906x.xx.xx0) .....	51
11	Data telegrams .....	53
11.1	Measured value telegram 1 .....	55
11.2	Measured value telegram 2 .....	57
11.3	Measured value telegram 400 .....	59
11.4	Forecast data telegram 401 ... 424 .....	60
11.5	Command interpreter MODBUS RTU (4.906x.xx.xx1) .....	61
11.5.1	Measured values (input register) .....	61
11.5.2	Commands (Holding Register) .....	68
11.6	Commands and description .....	68
11.6.1	Command AI .....	70
11.6.2	Command AP_PWD .....	70
11.6.3	Command BR .....	71
11.6.4	Command CI .....	72
11.6.5	Command DC .....	72
11.6.6	Command DO .....	73

11.6.7	Command FB.....	73
11.6.8	Command FW.....	74
11.6.9	Command HP .....	74
11.6.10	Command ID.....	75
11.6.11	Command KY.....	75
11.6.12	Command LC.....	76
11.6.13	Command LCFG.....	76
11.6.14	Command LCFG appskey.....	77
11.6.15	Command LCFG devaddr .....	77
11.6.16	Command LCFG nwkskey .....	78
11.6.17	Command: LCFG pwridx.....	78
11.6.18	Command: LCFG dr .....	79
11.6.19	Command: LCFG fsb .....	80
11.6.20	Command LDI.....	81
11.6.21	Command LDP .....	82
11.6.22	Command LRA .....	83
11.6.23	Command LL .....	84
11.6.24	Command LSD .....	85
11.6.1	Command MQ_THIES .....	85
11.6.2	Command MQ_ACT.....	86
11.6.3	Command MQ_NAME .....	86
11.6.4	Command MQ_USER.....	86
11.6.5	Command MQ_PW.....	86
11.6.6	Command MQ_PORT .....	87
11.6.7	Command RS .....	87
11.6.8	Command RD .....	88
11.6.9	Command SF.....	88
11.6.10	Command SH .....	88
11.6.11	Command SV.....	89
11.6.12	Command TR.....	89
11.6.13	Command TT.....	90
11.6.14	Command TZ.....	90
11.6.1	Command WL_NAME.....	91
11.6.2	Command WL_PW .....	91
11.6.3	Command XX.....	91
12	Technical data .....	92
13	Input circuitry .....	96
14	Dimensional drawing [in mm].....	97
15	Accessories (optional).....	98
16	Further information / documents for download .....	99
17	EC Declaration of Conformity.....	100
18	UK-CA-Declaration of Conformity .....	101

## **Table**

Table1	: MQTT channel ID .....	29
Table2	: LoRa - Coding of the data values.....	44
Table3	: LoRaWAN error code .....	47
Table4	: Status word .....	54
Table5	: Measured value telegram 1 .....	56
Table6	: Measured value telegram 2 .....	58
Table7	: Telegram 400 .....	59
Table8	: Telegram 401 ... 424.....	60
Table9	: MODBUS Frame .....	61
Table10	: MODBUS Exceptions. ....	61
Table11	: MODBUS Input Register.....	67

Table12 : Command list.....	69
Table13 : LoRa mask values of the measured values for LDP command .....	82
Table14 : Technical data .....	95
Table15 : Accessories .....	99

## **Illustration**

Figure 1: Elevation angle.....	8
Figure 2: Diagram of valuation characteristics .....	9
Figure 3: Spectrum of the brightness sensors .....	95
Figure 4: Spectrum for the global radiation sensor .....	95

## **Operating instructions**

These operating instructions describe all the possible uses and settings of the appliance.

With the help of these detailed operating instructions, the user can adapt the factory settings to their needs via the serial interface or wirelessly with the WLAN of the Weather Station Compact Advanced (WSCA). The LoRaWAN interface is used for data transfer and is not designed for device parameterization.

## **Scope of delivery**

The following parts are included in the scope of delivery:

- 1 x Weather Station Compact Advanced (WSCA)
- 1 x Mating connector for cable assembly for the sensor
- 1 x Operating instructions short version (enclosed in the package)
- 1 x Factory Settings (enclosed in the package)

The operating instructions for the WSCA can be downloaded from the following link:

[https://www.thiesclima.com/en/db/dnl/4.906x.00.x0x\\_wsca\\_eng.pdf](https://www.thiesclima.com/en/db/dnl/4.906x.00.x0x_wsca_eng.pdf)

For support with parameter settings and / or special configurations via the RS485 serial connection, our free "Device Utility Tool" Art. No. 9.1700.81.000 is available for download under the following link.

Link: <https://www.thiesclima.com/de/Download/>

In the "General" section, select the "Thies Device Utility" program.

Our free THIES-CUMULUS APP is available to support you with parameter settings and / or special configurations via wireless communication via WLAN. For more information, see [Commissioning with the Thies Cumulus app](#)

Download the APP THIES-CUMULUS at:

<https://www.thiesclima.com/de/Thies-Cumulus/>

# 1 Device versions

Order no.	Electrical output RS485	Wireless configuration	Wireless data transmission
4.9060.01.000 <sup>1</sup>	Data in ASCII format (command interpreter: THIES).	WLAN <sup>3</sup>	MQTT
4.9060.01.001 <sup>1</sup>	Data in binary format (command interpreter: MODBUS RTU).		
4.9061.01.000 <sup>1</sup>	Data in ASCII format (command interpreter: THIES).		LoRaWAN
4.9061.11.000 <sup>2</sup>			
4.9061.01.001 <sup>1</sup>	Data in binary format (command interpreter: MODBUS RTU). Data via LoRaWAN		
4.9061.11.001 <sup>2</sup>			

<sup>1)</sup> EU market <sup>2)</sup> US market <sup>3)</sup> Only WLAN networks with security level WPA2 are supported.

All versions with:

- Operating voltage 18 ... 30VDC or 18 ... 28VAC
- Interface: RS485 half-duplex
- Measurement data can be sent to an MQTT broker

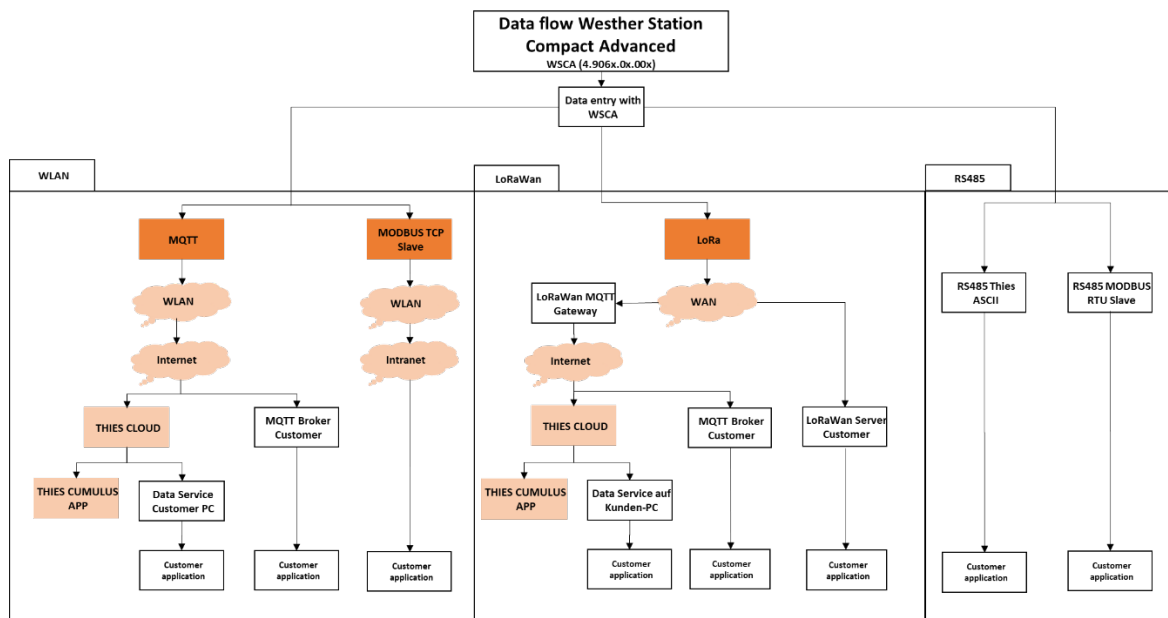

To use the device with LoRaWAN, we recommend using the LoRaWAN MQTT gateway. The gateway receives the LoRaWAN data and sends it to the Thies Cloud in MQTT format.

## 2 Application

---

The Weather Station Compact Advanced (WSCA) has been developed for use in building management systems, agriculture, traffic engineering and smart cities, it provides precise meteorological data and reliable forecast data and records the following measured variables:

- Wind speed
- Wind direction
- 3 x brightness (east / south / west)
- Twilight
- Global radiation
- Precipitation status
- Weather condition (frost, ice, snow, hail)
- Precipitation intensity levels (amount per time)
- Air temperature
- Absolute air pressure
- Relative air pressure
- Time / Date
- Geostationary data (local altitude, longitude and latitude)
- Position of the sun (elevation / azimuth)
- Absolute humidity
- Relative humidity
- Dew point temperature
- Forecast data (when used with WLAN and Thies Cloud)

All variants have a digital interface (RS485 interface in half-duplex mode). Together with ID-based communication, the interface enables the weather station to be operated in a bus. Depending on the device variant, the following data protocols are available:

- ASCII (THIES format).
- Binary (MODBUS RTU).

It is also possible to communicate with the device wirelessly via radio:

- WLAN (4.9060.xx.xxx)
- LoRaWAN + WLAN (4.9061.xx.xxx)

To use the device with LoRaWAN, we recommend using the LoRaWAN MQTT converter 9.1704.26.000. This converter receives the LoRaWAN data and sends it to the Thies Cloud in MQTT format.

### 3 Structure and mode of operation

#### Wind speed / wind direction

The wind measurement is based on the hot-wire principle. The heated cylindrical sensor is located in the base of the housing.

The rotationally symmetrical arrangement of the wind sensor in the housing base and the absence of interfering structural elements ensure direction-independent and uniform wind measurement from all directions.

The temperature of the cylinder is regulated by a controller at a temperature that is constantly higher than the ambient temperature. The heating energy supplied is a measure of the wind speed.

There are temperature measuring resistors inside the metal cylinder. These resistors are thermally coupled to the cylinder and arranged accordingly. When the air flows towards the cylinder, there is a temperature gradient depending on the wind direction, which is recorded via the measuring resistors. The wind direction is calculated based on the ratios of the temperature values. Rain-related influences on the wind sensor are reliably detected and reported by analyzing thermal measurement differences.

If the wind direction cannot be determined because the wind speed is 0m/s, its value is set to 0°. Wind from the north is mapped with 360°.

#### Brightness

The brightness is measured via 3 silicon photo sensors, which are aligned in 3 cardinal directions with an elevation angle corresponding to the display See Figure 1. The evaluation characteristic as a function of the position of the sun is shown in Figure 2 (diagram).

The influence of diffuse reflected radiation from the housing is effectively minimized by design measures. This improves the measuring accuracy in particular when the sun is low in the sky.

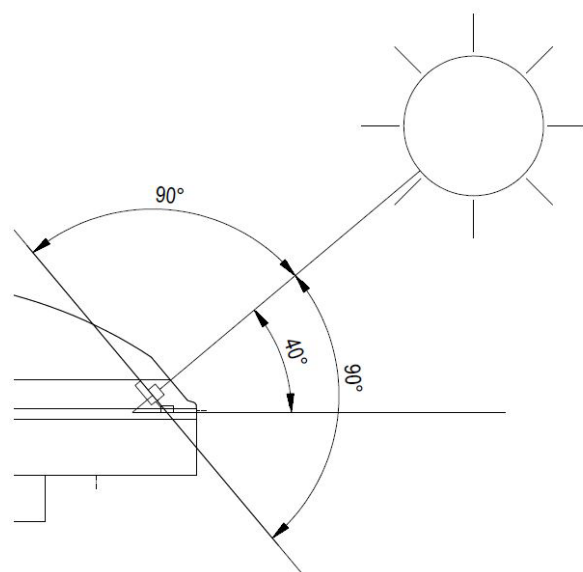

Figure 1: Elevation angle

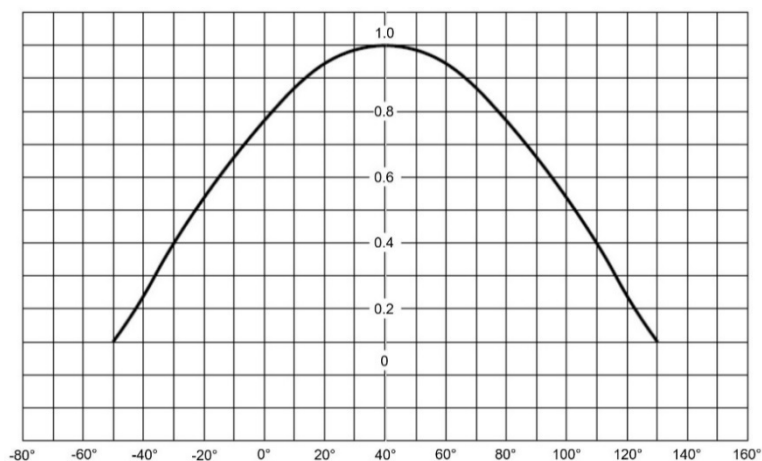

Figure 2: Diagram of valuation characteristics

See Figure 3: Spectrum of the brightness sensors

## Twilight

Twilight is the scattering of light in the atmosphere that occurs during the smooth transition between day and night before the beginning or after the end of the day.

This means that the solar disk is not visible.

Twilight is independent of direction.

It is calculated from the sum of the 3 measured values of the direction-dependent brightness sensors. It is also possible to switch to the average value from the 3 brightness values using a command.

## Global radiation

Global irradiance is measured using a silicon photodiode. The sensor is arranged horizontally and records the daily variation in solar irradiance. See Figure 4: Spectrum for the global radiation sensor

## Precipitation

Precipitation detection is based on a capacitance measurement, i.e. the capacitance of the sensor surface changes when it is wet. The sensor is mounted in the housing cover. An integrated heater regulates the sensor surface to an excess temperature compared to the ambient temperature. This excess temperature (approx. 2K) prevents condensation from forming on the sensor surface. The heating output is increased during precipitation. This accelerates the drying of the sensor and the end of precipitation can be detected more accurately.

If hail is detected, only the hail detection flag is set. The precipitation flag is only set if the hail also contains liquid precipitation.

The determination of the precipitation intensity is based on the evaluation of the change in capacity. The precipitation intensity is added up according to the quantity and time of the last minute and then reset to 0.

Further information on precipitation analysis can be found at:

<https://www.thiesclima.com/en/solid-liquid-precipitation-THERMACERN/>

## Weather condition

The weather condition is an indicator calculated from current and past measured variables that currently indicates winter conditions. The calculation includes precipitation events from the last 12 hours, as well as the current temperature and the current precipitation status. Depending on these conditions, current snowfall, frost and ice conditions are indicated. This function proves useful for building control. Initial values are used that have proven to be suitable for this application. A microphone is built into the sensor to detect hail.

## Air temperature

The air temperature is measured via a PT1000 measuring resistor. The sensor is mounted on a flexible circuit board and placed in the lower part of the housing.

## Air pressure

The absolute air pressure is measured via a piezoresistive MEMS sensor. In order to be able to meaningfully compare air pressure values measured at different locations at the same time, **they must be converted to a common reference altitude (sea level)**. The calculation is based on sea level (QNH) according to the international altitude formula (DIN ISO2533).

$$p(h) = p_b \left(1 + \frac{\beta}{T_b} \cdot h\right)^{-\frac{g_n}{\beta \cdot R}}$$

$P_h$  = Air pressure at local altitude

$P_b$  = Air pressure at sea level

$\beta$  = -0065K/m

$g_n$  = 9.80665m/s<sup>2</sup>

$R$  = 287.05287m<sup>2</sup>/K/s<sup>2</sup>

$T_b$  = 288.15K

The station height required for the calculation can be entered manually using the Command SH or determined automatically using GPS.

If you want to achieve an accuracy of 0.1hPa in relation to sea level, the local altitude (height of the barometer) must be known to an accuracy of 0.8m.

### **Time / date and geostationary data**

The weather station has a GPS receiver with integrated RTC. This receives the position of the weather station (longitude, latitude, altitude), the time (UTC) and the date. Alignment of the GPS receiver is not necessary.

The integrated RTC (Real Time Clock) is buffered with a backup capacitor and retains its data without supply voltage for a period of at least 3 days.

### **Position of the sun (elevation / azimuth)**

The current position of the sun is calculated every second using the GPS data.

### **Moisture measurement**

Humidity is measured via an integrated hygrothermal sensor. Due to its miniature housing, the sensor has a small air exchange volume and reacts to changes in humidity within seconds.

A software module calculates the absolute humidity and the dew point temperature from the relative humidity and the air temperature.

### **Internal housing temperature**

The temperature inside the housing is measured using a silicon temperature sensor.

## GPS receiver

The weather station has a GPS receiver with integrated RTC (Real Time Clock), which receives the position of the weather station and the time + date (UTC).

Alignment of the GPS receiver is not necessary.

The integrated RTC is buffered over a period of 3 days.

General information:

After switching on the Weather Compact Advanced (WSCA), the first satellite data is available after approx. 2.5 minutes.

When the signals are received:

- of a satellite Time with an accuracy  $< 1\mu\text{s}$ .
- from three satellites: Position with an accuracy  $< 20\text{m}$
- of four satellites: Altitude, relative to the WGS84 ellipsoid, with an accuracy  $< 30\text{m}$

The well-known "rollover" effect is intercepted in the software. Any necessary date correction is carried out using the firmware date so that the date is valid for at least 20 years after each software update.

## 4 Installation and choice of location

---

### **Attention:**

***The Weather Station should be used in a horizontal position (plug connection at the bottom).***

***When installing, removing, transporting or maintaining the Weather Station, make sure that no water enters the device and plug.***

### 4.1 Choice of installation location

An exposed location should be selected for the site. Wind shadow, light reflection and shadows must not affect the measurement properties.

Surge and lightning protection should be taken into account on site.

## 4.2 Mechanical assembly

The weather station installed as intended on a pipe socket / pipe with an **outer diameter of  $\leq 25\text{mm}$** . The **inside diameter must be  $\geq 19\text{mm}$**  in order to be able to feed plugs and cables through.

**Tool:**

Allen key SW2mm.

**Procedure:**

1. Feed the cable / plug connection through the hole in the mast, tube, bracket, etc.
2. Attach the weather station to the mast, pipe.
3. Align the weather station to "North" (see chapter 4.2.1 for the procedure).
4. Secure the weather station with the M4 hexagon socket head screw.

**Caution:**

*The hexagon socket screw must be tightened to max. 0.6Nm.*



## 4.2.1 North orientation

The weather station must be mounted facing **north** (true north) in order to determine the exact direction of the wind and brightness.

**The marking on the sensor base serves as the north marking (N)**

**Tool:**

Allen key SW 2mm.

**Procedure:**

1. Locate a prominent point in the landscape (tree, building, etc.) in a northerly direction using a compass.
2. The weather station is to be aimed at the prominent point via the north marker (N) and an imaginary north-south axis.
3. Align the weather station.  
The north mark (N) must point to *true north*.
4. The weather station must be secured with the M4 hexagon socket head screws if they match.



**Caution:**

**The hexagon socket screw must be tightened to max. 0.6Nm.**

**Note:**

When aligning to north using a compass, the misalignment (deviation of the direction of a magnetic needle from the true north direction) caused by interfering magnetic fields and magnetic field influences from iron parts and electrical cables must be taken into account.

With the help of the compact traverse adapter (article number 511103), the north alignment can be achieved by means of a hole in the adapter.

## 4.3 Electrical installation

The weather station is equipped with a 7-pin plug for the electrical connection. A cable socket (mating connector) is included in the scope of delivery.

### 4.3.1 Cables

The cable to be connected should have the following properties:

5 cores, max. 0.14mm<sup>2</sup> core cross-section, cable diameter max. 5.0mm, UV resistance, over-all shielding.

**Note**

A pre-assembled connection cable can be supplied as an option. Please see [Accessories \(optional\)](#)

Cable socket, type: Binder, Series 711

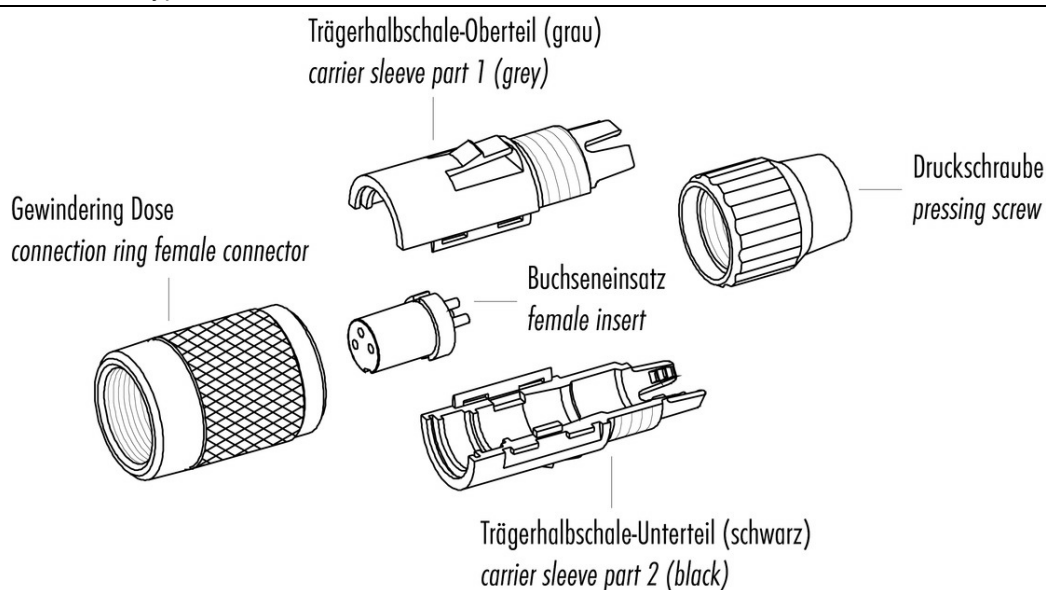

**Achtung:** max. Drehmoment des Gewinderinges im Flanschsteckverbinder: 50cNm (handfest)  
**Attention:** max. torque of ring nut in socket connector: 50cNm (manual adjustment)

**Attention:**

**For long cable connections, the voltage drop on the cable must be taken into account so that the required supply voltage is applied to the weather station.**

Calculation of the voltage drop on the cable.  $U_{Ltg} = R_L * I$ ;  $R = 2 * l * \rho / A$ ;  $\rho$  (rho) = 0.018

Example:  $I = 0.3A$ ,  $A = 0.14mm^2$ ,  $L = 100m$

$R = 2 * l * \rho / A$ ,  $R = 25.7\Omega$

$U_{Ltg} = R_L * I$ ,  **$U_{Ltg} = 7.7V$**

### 4.3.2 Wiring diagram

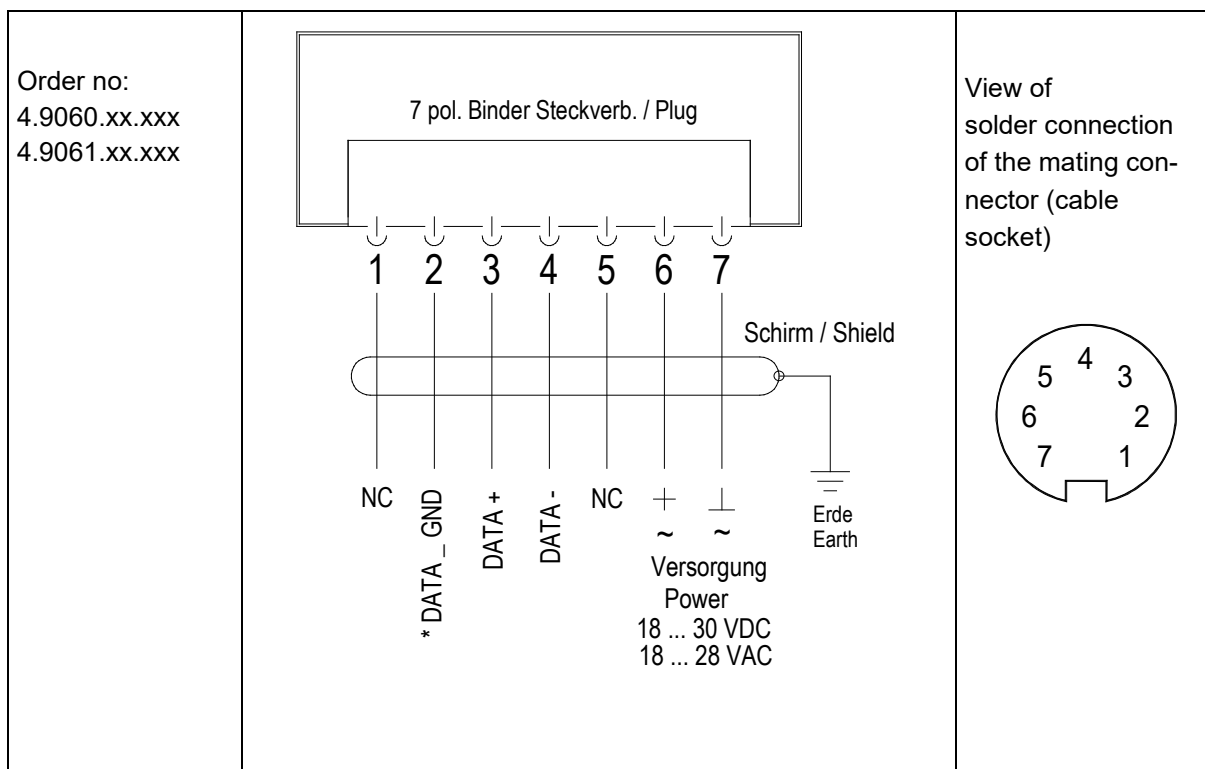

\* For long transmission distances, a connection to the GND of the data acquisition system can reduce the susceptibility of the transmission path to interference.

**Important:**

(\* Do not connect DATA \_ GND to the supply voltage GND).

### 4.3.3 Connection for 5-core cable Article no. 510023 / 510024 / 510197

PIN	Wire color	Function
1		NC
2	WHITE	* DATA _ GND
3	BROWN	DATA +
4	GREEN	DATA -
5		NC
6	YELLOW	+ Supply 18...30VDC / 18...28VAC
7	GRAY	- Supply 18...30VDC / 18...28VAC

\* For long transmission distances, a connection to the GND of the data acquisition system can reduce the susceptibility of the transmission path to interference.

**Important:**

\* Do not connect DATA \_ GND to the supply voltage GND.

## 5 Commissioning MQTT / LoRaWAN

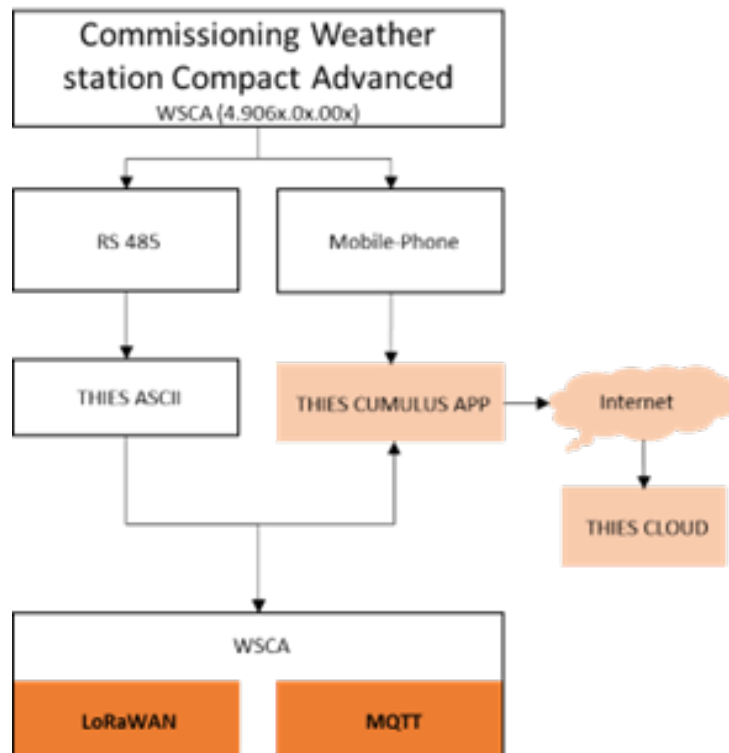

## 6 WLAN

The weather station has an internal WLAN module in all expansion stages. The WLAN module is used for commissioning the weather station and for data transmission. In the device variant with LoRaWan, the WLAN module is only used for commissioning. Data is transmitted via LoRaWan. The sensor works in WLAN networks with 2.4GHz.

### 6.1 Function of the WLAN module

Internally, the sensor provides two WLAN connections:

- A separate WLAN network, which is called "AP mode". This network is used during the initial start-up. It is used to set up the second Wi-Fi connection so that the WSCA can access the actual Wi-Fi network.
- A WLAN client for accessing your own WLAN network.

The MQTT protocol is used internally for data transmission via the WLAN. The sensor is pre-set that the data packets are sent to the THIES cloud via MQTT. However, it is also possible to configure the sensor to send the data separate to MQTT server.

The following parameters are available via the command interface to configure the MQTT connection.

MQ\_ACT  
MQ\_THIES  
MQ\_Name  
MQ\_User  
MQ\_PW

The MQ\_THIES parameter specifies whether the station should connect to the Thies Cloud. If MQ-THIES is 1, the WSCA connects to the Thies cloud "www.thiescloud.com"

## 6.2 Commissioning the WSCA via WLAN

The Thies Cumulus app (for mobile devices) is available for commissioning the WSCA. The Cumulus app can be downloaded for Android (from version 14) and IOS (from version 16.x.x) from the manufacturer's stores.

## 6.3 Commissioning with the Thies Cumulus app

For commissioning via the Thies Cumulus app, the Thies Cumulus app (V1.2.6 or higher) must first be installed via the App Store (iOS) or Play Store (Android). If no user account exists yet, a user account must first be created after starting the app. See also the Thies Cumulus APP 9.1780.00.000 FAQ.

Link: [https://www.thiesclima.com/db/dnl/9.1780.00.000\\_Thies\\_Cumulus\\_App\\_FAQ\\_en.pdf](https://www.thiesclima.com/db/dnl/9.1780.00.000_Thies_Cumulus_App_FAQ_en.pdf)

When using the Thies Cumulus App, the WSCA can immediately transmit the data to the Thies Cloud after connecting to the local WLAN and retrieve the data from there. The data can be retrieved via the Thies Cumulus App via Thies Cumulus Web App or via PC / Linux utilities. When using the Cumulus APP, the current measured values are displayed on the app immediately after installation.

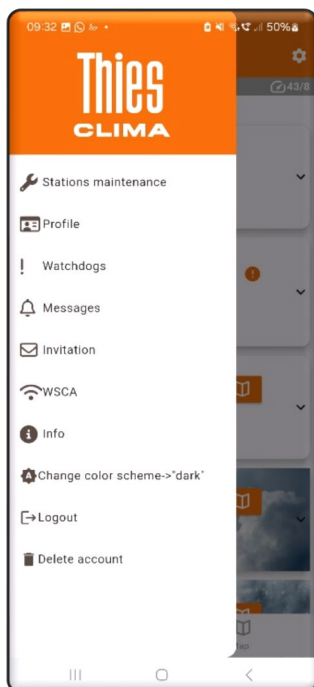

After starting the app, the sensor search can be selected via the "WSCA" menu.

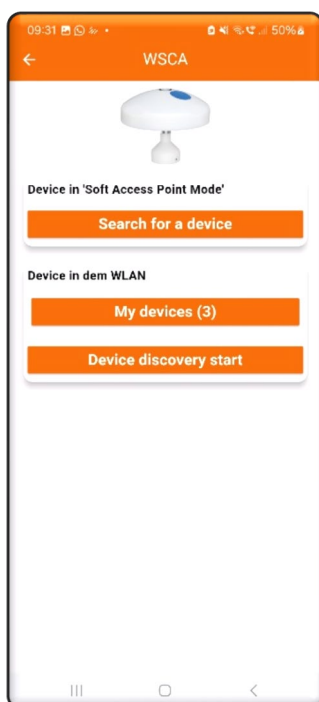

A dialog appears in which you can choose between searching for a new sensor and displaying existing sensors. To set up a new sensor, the "Search device" button must be pressed here.

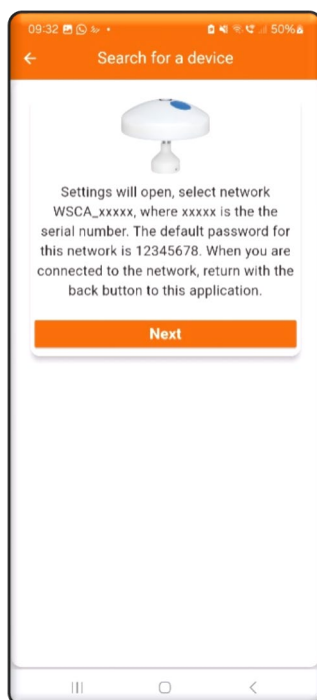

This is followed by a dialog with a description of the cell phone settings. These settings cannot be made automatically and differ depending on the cell phone used. In the next step, the WLAN connection to the WSCA must be established. The WSCA provides its own WLAN network for this purpose (SoftAP mode). The network name begins with "WSCA\_" followed by the serial number.

If the sensor has not yet been connected to a WLAN, SoftAp mode is always active. If a WLAN connection has already been established, SoftAp mode is active for 5 minutes after the restart and is then switched off.

After clicking "Next", a dialog for selecting the Wi-Fi network opens. In this example, the WLAN network has the name WSCA\_04711. The WSCA network must now be selected.

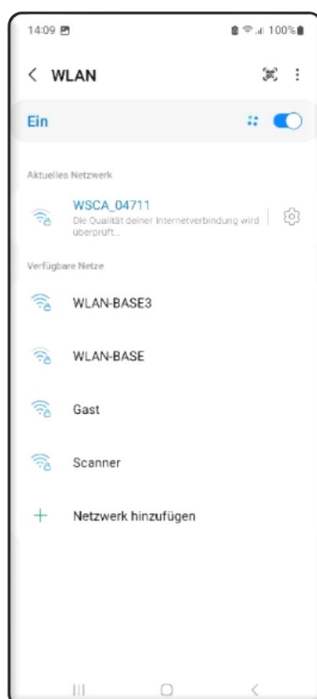

The initial WLAN password for the WSCA is:  
12345678

Once the connection has been established, you can switch back to the Thies Cumulus app.

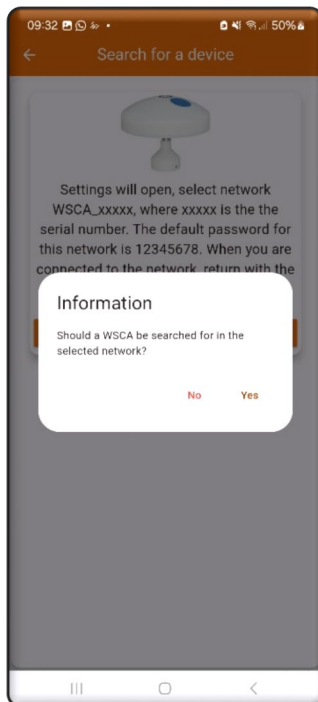

A dialog appears indicating that the WSCA search is about to start. The search is started by pressing "Yes".

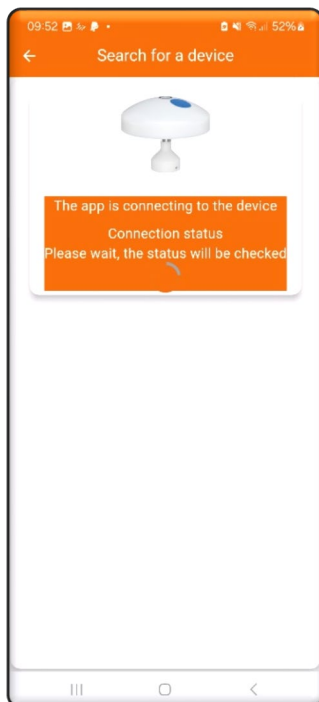

The app connects to the WSCA in the specified network.

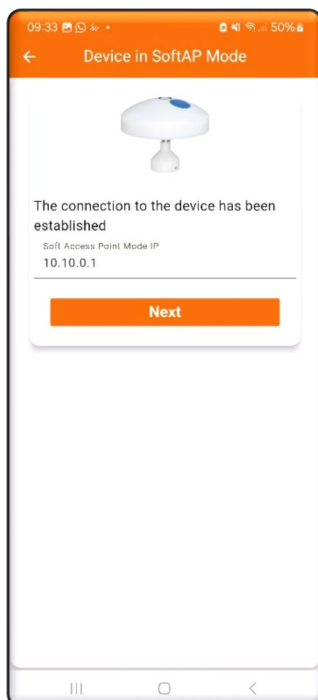

If a connection to the WSCA has been established, this information is displayed in the dialog. The IP address of the WSCA is always 10.10.0.1 In this step, the cell phone must still be connected to the WLAN "WSC\_xxxxx" (with xxxxx of the serial number).

After clicking "Next", a dialog with the WLAN settings appears.

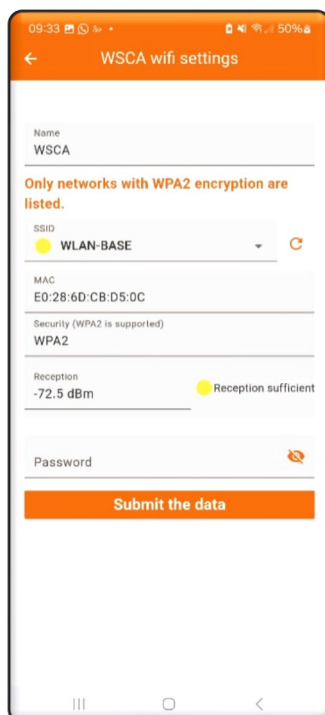

In this dialog, the Wi-Fi network that is also used for the cell phone's Internet connection must be selected. In this example, the WLAN has the name "Weather gate" The password for the WLAN network must also be entered. The "Reception" field shows the reception quality of the WLAN network of the WSCA. The reception quality must be at least yellow (good) or green (very good).

In this case, the WLAN signal from "Weather-Gate" is very poor for the WSCA and should not be used. The name of the WLAN network must not contain three consecutive '#', e.g. NetWork### is not a valid name.

In the default settings, the WSCA automatically connects to the Thies cloud and sends the data there. Data is transferred via MQTT. This can be changed later in the device settings.

After pressing the "Submit the data" button, the installations are transferred to the WSCA.

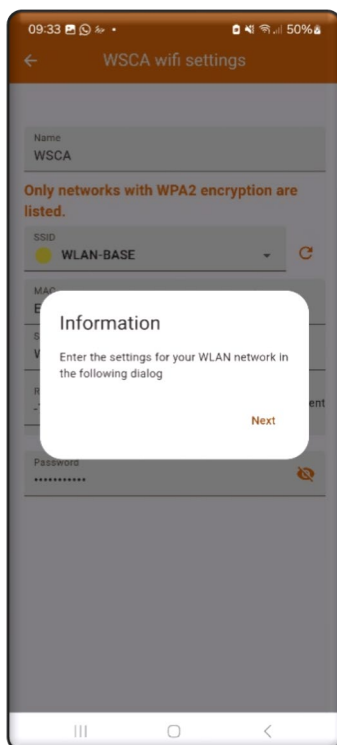

The local WLAN has now been configured in the WSCA. The cell phone must now be reset to the local WLAN. It is the identical network that was entered in the WSCA in the previous dialog.

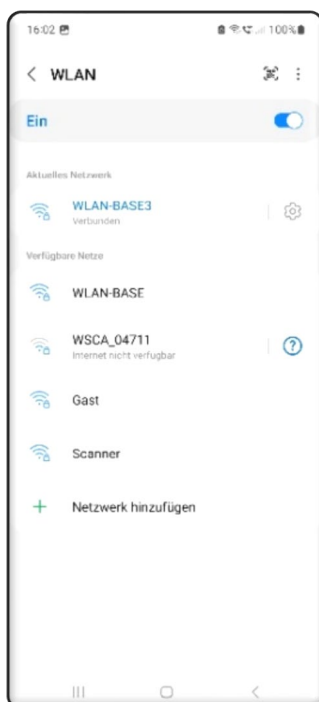

Select and connect WLAN accordingly.

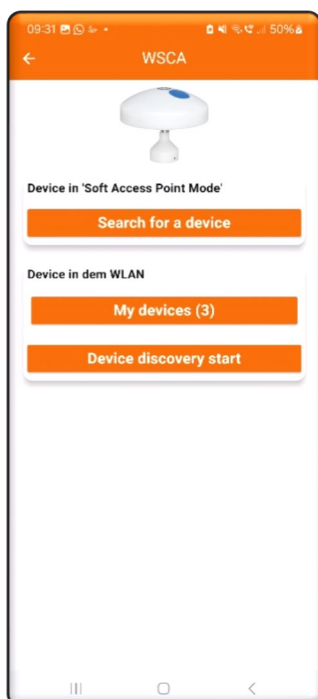

After completing the configuration, press the “Device discovery start” button. All WSCA modules in the local network are then searched for and displayed under “My devices”.

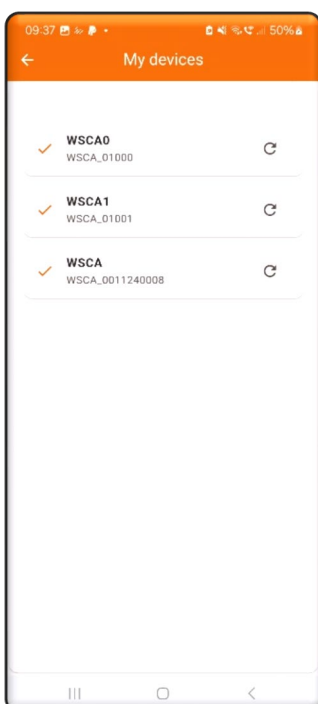

Once the configuration is complete, the sensor appears in the station list under My devices and the station list.

Individual buttons / menu items can be used to configure WSCA parameters, analyze and evaluate data.

The picture shows the possibilities for the WSCA with WLAN.

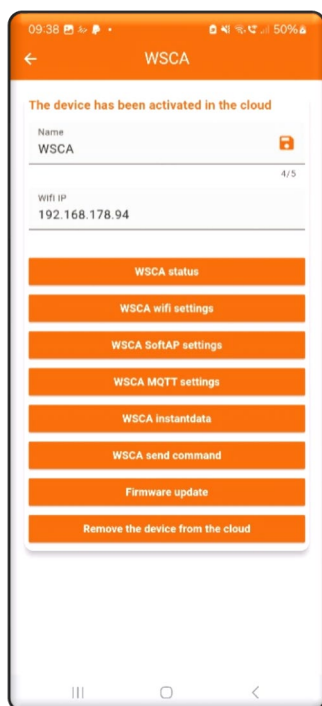

WSCA status: Displays the status information of the device.

WSCA Wifi settings: Defines the settings of the locally used WLAN.

WSCA Soft AP settings: The WSCA provides its own WLAN network using the Soft AP mode. This network is used when the WSCA is commissioned. Soft AP mode can be password protected.

WSCA MQTT settings: The parameters for the MQTT server used are set under this item. If a WLAN connection is available, the data is sent cyclically to the server every three seconds.

WSCA current values: Displays the currently measured values of the WSCA.

Send WSCA command: This dialog can be used to send commands to the weather station. Commands can be entered and sent via the +. E.g. BR to query the baud rate of the RS485 interface.

Update firmware: This button calls up the firmware update dialog. The sensor has two internal processors, a main controller and a WLAN controller. Both controllers can be updated with new firmware if required.

## 6.4 Connect with another MQTT broker

The WSCA supports data transfer to an MQTT broker that is not the Thies Cloud. To do this, it is first necessary to integrate the sensor into the Thies Cloud, see 6.2 . The used MQTT broker can be changed afterwards.

Proceed as follows:

Integrate the sensor in the Thies Cloud as described at 6.2 .

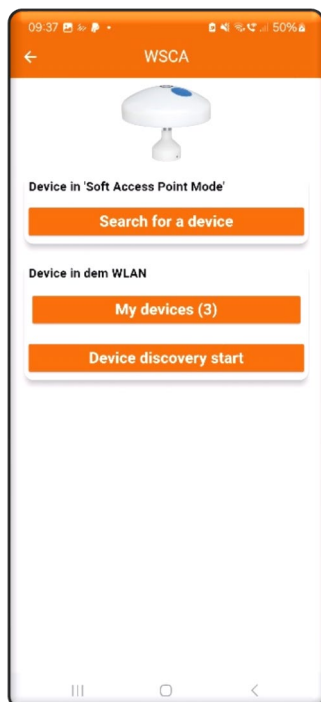

Select the WSCA menu item in the Thies Cumulus app.

Press the " Device discovery" button. At least the previously configured device must now be displayed in the sensor list. Now press the "My devices" button.

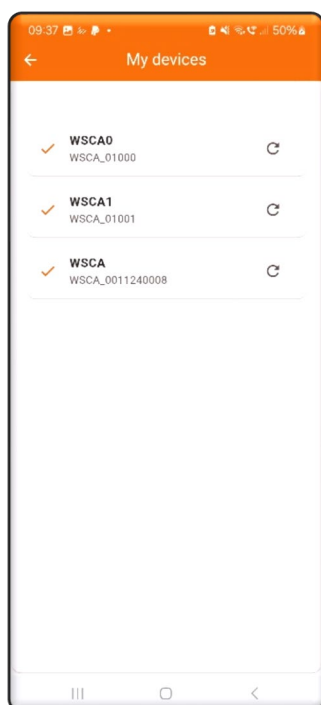

Your own device must be displayed in this dialog. Click on this device. A dialog opens with various setting options.

The name is composed of WSCA + serial number.

Note: The serial number can be found on the type plate of the WSCA.

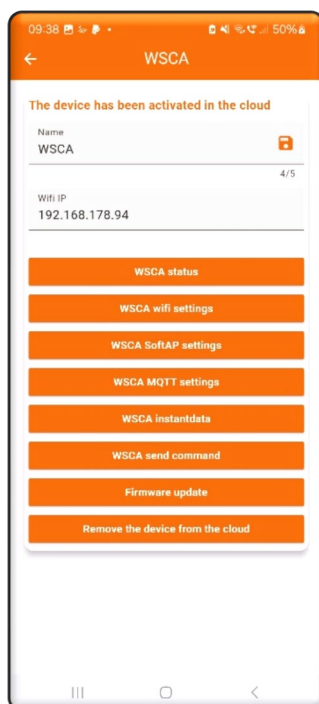

Select the "WSCA MQTT settings" button.

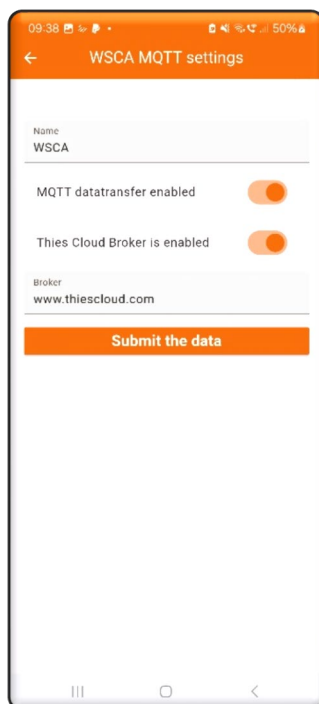

In this dialog, deselect the slide switch "The Thies Cloud Broker is enabled".

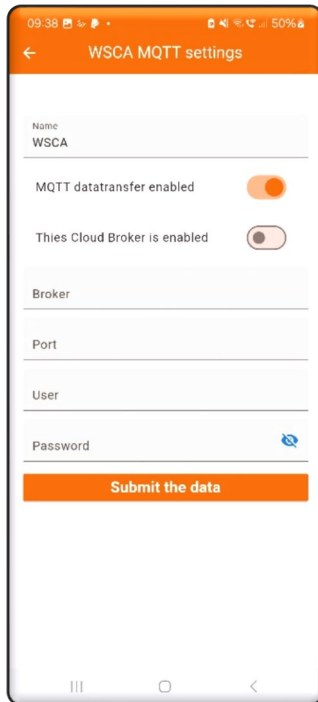

Now enter the relevant data in the Broker, Port, User and Password fields and press the "Submit the data" button. Then restart the WSCA; this can be carried out using the RS2 command.

#### 6.4.1 Data on the MQTT broker

The data is transferred to the "GUID" dataall topic, whereby the GUID is the device GUID without "-". The device GUID is displayed in the Thies Cumulus app under "WSCA status" in the "Device GUID" field. It is a 32-character number.

The transmitted data has the following form:

Date;Time#Channel ID;Measured value;Status# Channel ID;Measured value;Status#.....  
Channel ID;Measured value;Status#

e.g.

```
2024-04-17;11:17:52#00;000.5;0000#01;042.3;0000#02;000.0;0000#
03;999;0000#04;0806;0000#05;012.0;0000#06;0;0000#07;02.5;0000#08;178;0000
#09;0986.7;0000#10;0986.7;0000#11;031.7;0000#12;004.69;0000#13;000.1;0000
#14;0010.011225;0000#15;051.493283;0000#16;049.7;0000#17;179.3;0000
#18;00000001;0000#
```

The MQTT channel ID stands for the measured value type.

Measured value	MQTT channel ID	Unit of measurement
Brightness East	00	kLux
Brightness South	01	kLux
Brightness West	02	kLux
Twilight	03	Watt
Global radiation	04	Watt
Air temperature	05	°C
Precipitation yes / no	06	0 / 1
Wind speed	07	m/s
Wind direction	08	°
Absolut. air pressure	09	hPa
Relativ air pressure	10	hPa
Relativ humidity	11	% rel. H.
Absolut humidity	12	g/m <sup>3</sup>
Dew point temperature	13	°C
Longitude (longitude)	14	°
Latitude (degree of latitude)	15	°
Sun position Elevation	16	°
Sun position Azimuth	17	°
Sensor status	18	Binary value, see Table 4, status word
Station height	19	m
Weather condition	20	Value Bit coded  Bit0 Frost Bit1 Ice Bit2 Snow Bit3 Hail
Precipitation intensity levels	21	0 no to minimal drop 1 light precipitation 2 moderate precipitation 3 heavy precipitation

Table 1 : MQTT channel ID

## 6.5 Integrate WSCA into your own group

When commissioning the sensor, the default setting is to log the sensor into the Thies Cloud. During this registration, the sensor is assigned to the person who registers the device. The person logging in is always a member of a group. By default, the person is a member of the "Public" group. When commissioning a new device, the logged person has the option of creating their own group. See also

[https://www.thiesclima.com/db/dnl/9.1780.00.000\\_Thies\\_Cumulus\\_App\\_FAQ\\_de.pdf](https://www.thiesclima.com/db/dnl/9.1780.00.000_Thies_Cumulus_App_FAQ_de.pdf)

To create your own group when registering the WSCA, proceed as described below. It is necessary for the WSCA and the cell phone to be in the same WLAN network.

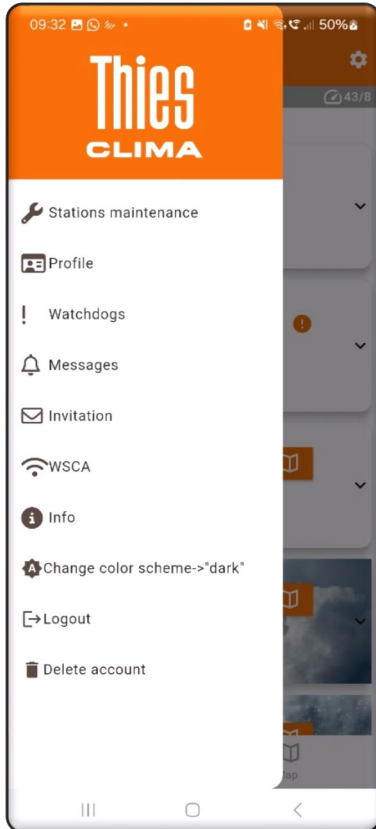

1. Commissioning the WSCA in the Thies Cloud as described above.
2. Then open the station management in the Thies Cumulus app via the main menu.

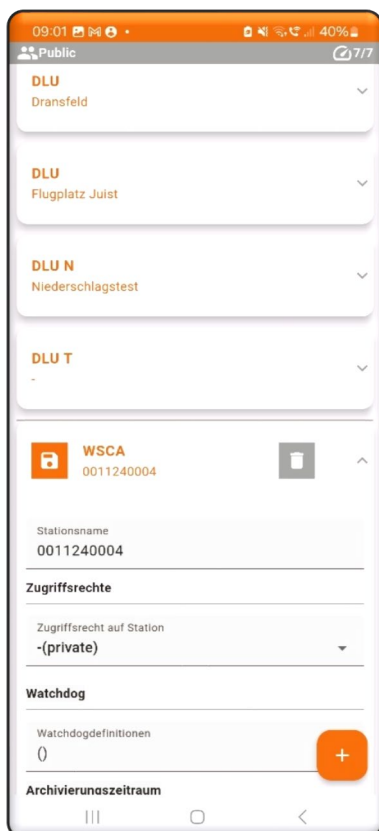

3. Select the desired station in the list and log off the station using the trash symbol.

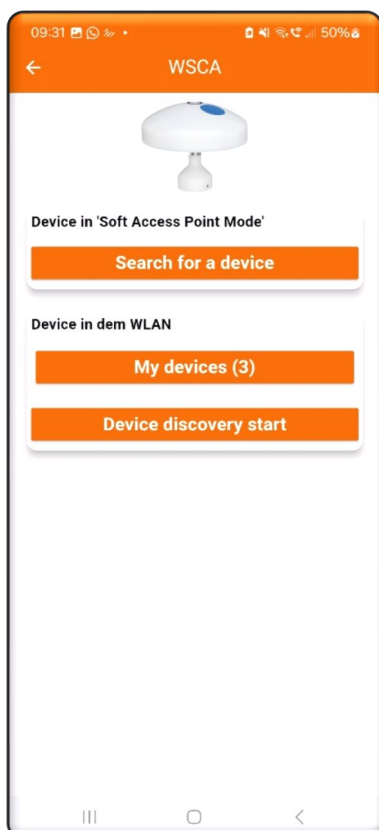

4. Select the “WSCA” entry via the main menu and use the “Device discovery start” button to search for the current devices in the WLAN. The previously logged off device must now be found during the search.

5. Select the previously logged off device via the “My devices” button.

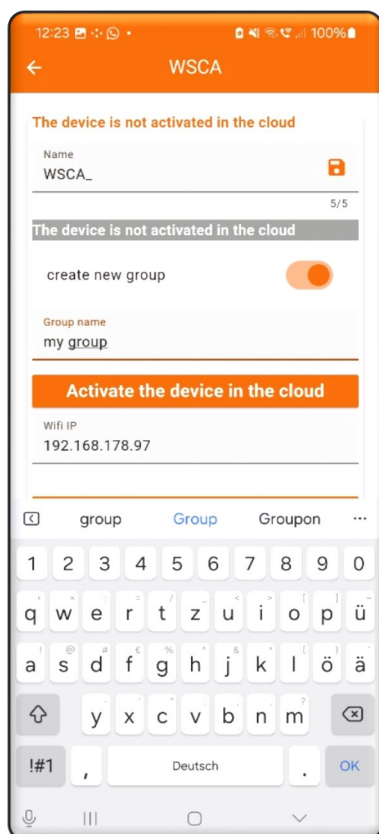

6. A prompt appears asking whether the device should be activated in the cloud. Confirm this prompt with “Cancel”.

7. In the following dialog, a switch is visible to indicate whether a separate group should be created when the sensor is created. Activate the switch and enter the name of your own group.

8. Select “Activate the device in the cloud”. A new group is now created. You automatically switch to the new group with all the sensors registered for you.

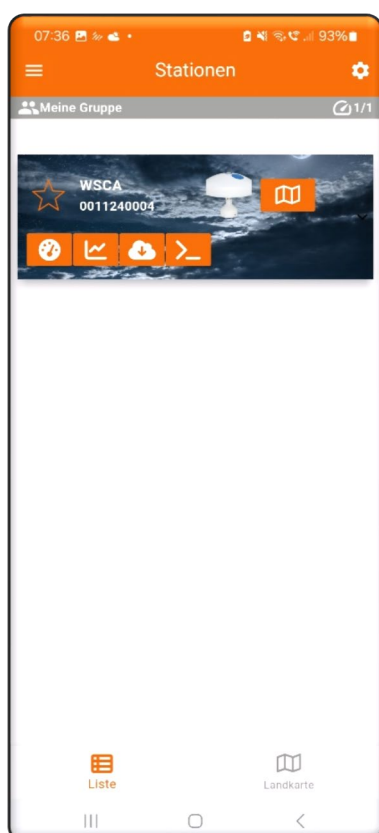

## 6.6 MODBUS TCP

From software version 1.7.3 of the WLAN module, the WSCA supports data retrieval via MODBUS TCP Access via MODBUS TCP is via the IP address and port 502. Any address between 0 and 255 can be selected for the MODBUS address.

The IP address of the sensor is obtained as follows:

1. restart the sensor
2. select the WLAN of the WSCA on the mobile device (SoftApMode)
3. start the Internet browser on the cell phone
4. select the IP address 10.10.0.1. The WSCA web page will now appear. The IP address is displayed on the status page under the "Wifi" section.

In the example, the IP address of the device is 192.168.178.164

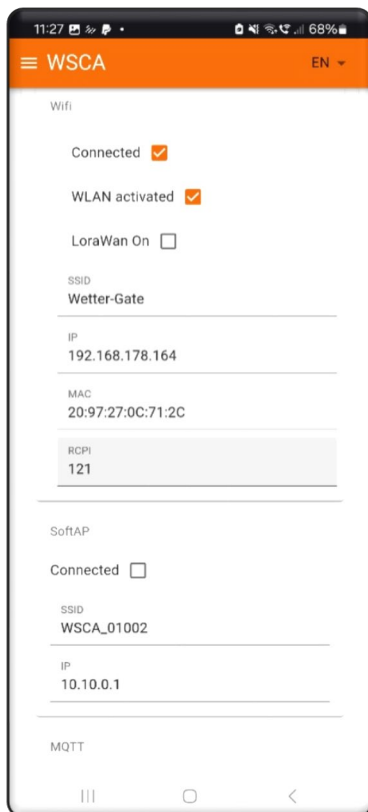

## 7 LoRaWAN - Low Power Wide Area Network

---

In the 4.9061.0x.xxx und 4.9061.1x.xxx expansion stage, the WSCA has an internal WLAN and LoRaWAN module. The WLAN module is used for configuration and the LoRaWAN module for data transmission.

The sensor supports APB and OTAA modes. These modes can be switched using the LRA parameter. Depending on which mode is activated, different parameters must be communicated to the LoRa remote station.

The transmission interval and data rate can be set. Depending on the intended application area, Europe or North America, a different LoRaWAN chip is installed in the WSCA, ensuring that the specified transmission parameters, such as the transmission frequency, are adhered to. It is not permitted to use a LoRaWAN device manufactured for the European market in North America. The same applies to a LoRaWAN device manufactured for the North American market when used in Europe.

Item number	Area of application
4.9061.0X.XXX	Europe
4.9061.1X.XXX	North America

The data is transmitted to the LoRaWAN network in binary format. The WSCA transmits the data values specified by the LDP parameter.

### 7.1 Communication in APB Mode

Three values must be entered in the LoRaWAN gateway; the WSCA then sends the data directly to the LoRaWAN network:

- Device address (Dev ADDR) is listed on the nameplate
- APP Session Key: 00112233445566778899AABBCCDDEEFF  
(default hexadecimal value)
- Network Session Key: 00112233445566778899AABBCCDDEEFF  
(default hexadecimal value)

It is recommended to change the values for “APP Session Key” and “Network Session Key.”

## 7.2 Communication in OTAA mode

In OTAA mode, the parameters `deveui`, `appeui` (now `joineui`), and `appkey` (not to be confused with `appskey`) must be entered on the remote device. The values can be read using the Cumulus app and are also listed on the included configuration sheet.

Additional settings for OTAA mode are as follows:

MAC Version: 1.0.2 (as of March 2026)

Revision: A

The LoRaWAN chip used internally can be queried using the LL command. The response contains the LoRaWAN chip used and the chip's software version. With this data, additional information about specific characteristics of the LoRaWAN chip can be downloaded from the Internet.

## There are two options for commissioning the WSCA with

### LoRaWAN:

- With the Thies Cumulus App 7.3.
- With the serial RS485 interface 7.4.

## 7.3 Commissioning with the Thies Cumulus app

The required parameters for LoRaWAN can be configured via the Thies Cumulus app. Various settings are necessary for the sensor to operate in a LoRaWAN network.

First, you must select the communication mode: APB or OTAA. Different parameters are active depending on this setting.

For APB mode:

- The device address (DEV-ADDR)
- The application key (App Session Key)
- The network key (Network Session Key)

For OTAA mode:

- Device EUI (`deveui`)
- Join EUI (formerly: App EUI) (`appeui`)
- App Key (`appkey`)

The data rate and transmission interval are also required for operation.

All three keys are set to meaningful values on delivery and can be changed by the user.

For commissioning via the Thies Cumulus app, the Thies Cumulus app must first be installed via the App Store (iOS) or Play Store (Android). If no user account exists yet, a user account must first be created after starting the app. See also the Thies Cumulus App 9.1780.00.000 FAQ operating instructions.

Link: [https://www.thiesclima.com/db/dnl/9.1780.00.000\\_Thies\\_Cumulus\\_App\\_FAQ\\_de.pdf](https://www.thiesclima.com/db/dnl/9.1780.00.000_Thies_Cumulus_App_FAQ_de.pdf)

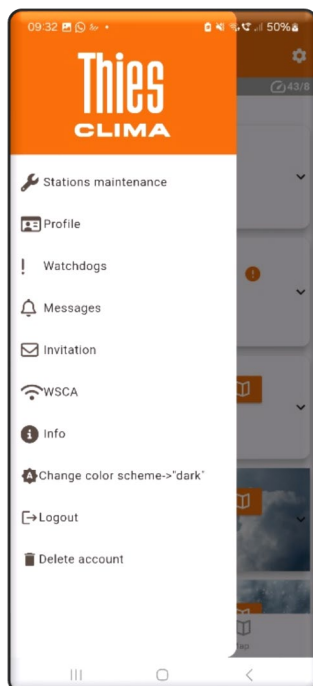

After starting the app, the sensor search can be selected via the "WSCA" menu.

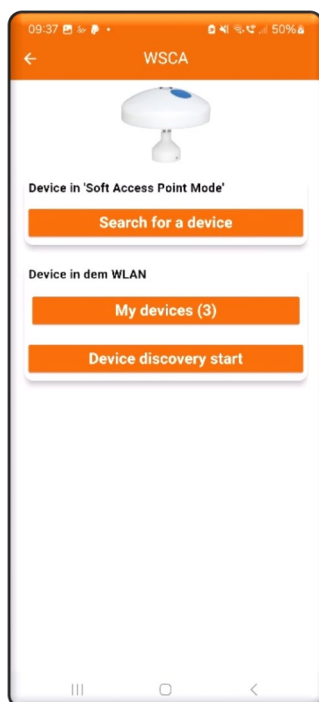

A dialog appears in which you can choose between searching for a new sensor and displaying existing sensors. To set up a new sensor, press the "Search device" button.

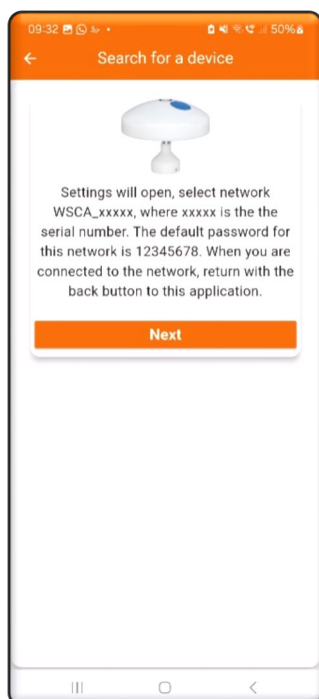

This is followed by a dialog with a description of the cell phone settings. These settings cannot be made automatically and differ depending on the cell phone used. In the next step, the WLAN connection to the WSCA must be established. The WSCA provides its own WLAN network for this purpose (SoftAP mode). The network name begins with "WSCA" followed by the serial number.

After clicking "Next", a dialog for selecting the WLAN network opened.

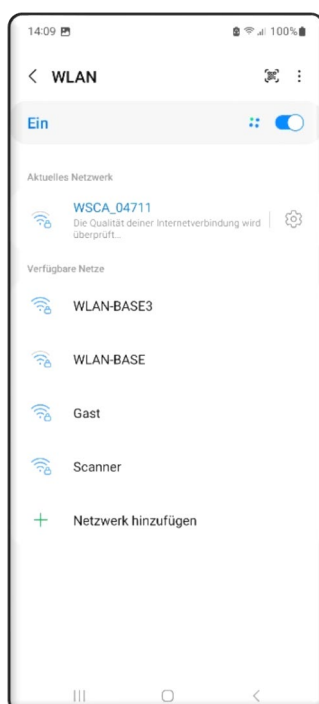

In this example, the WLAN network has the name WSCA\_04711. The WSCA network must now be selected.

The initial WLAN password for the WSCA is:  
12345678

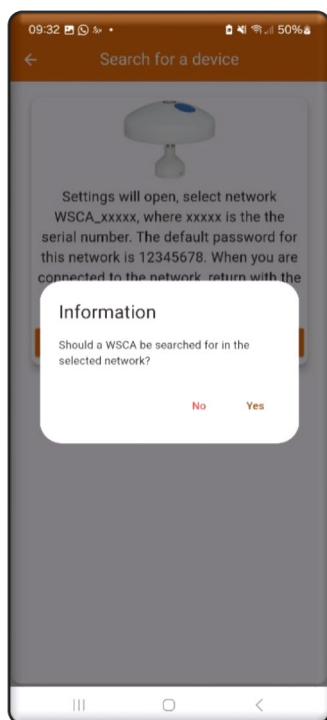

A dialog appears indicating that the WSCA search is about to start. The search is started by pressing "Yes".

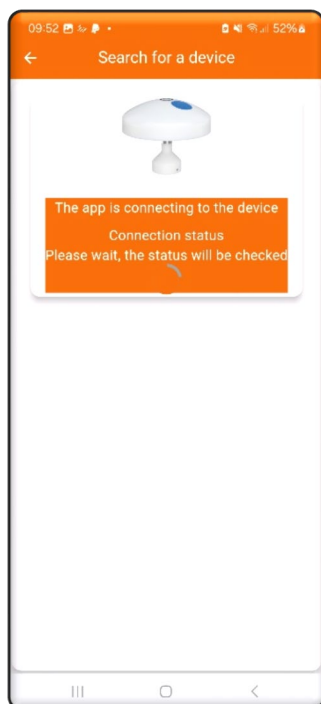

The app connects to the WSCA in the specified network.

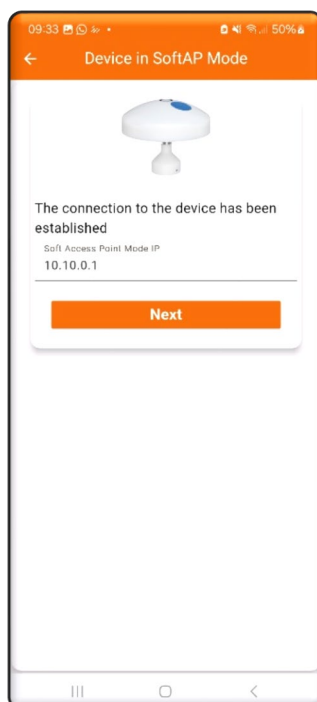

If a connection to the WSCA has been established, this information is displayed in the dialog. The IP address of the WSCA is always 10.10.0.1 In this step, the cell phone must still be connected to the WLAN "WSC\_XXXX" (with XXXXX the last 5 digits of the serial number).

After clicking "Next", a dialog with the settings appears.

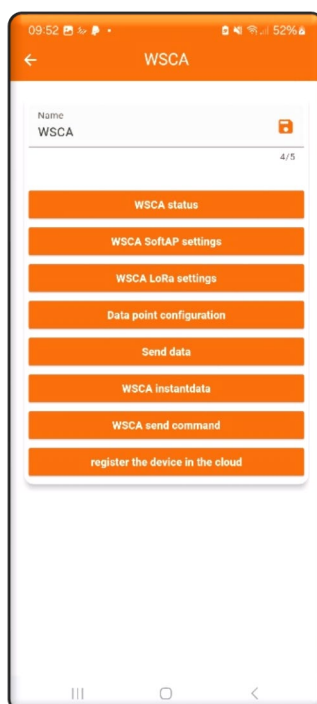

The dialog shows the categories for possible settings. Pressing the "WSCA LoRa settings" button displays the dialog for setting the LoRaWAN parameters.

**Note:**

***In the "Send WSCA command" dialog, the commands must be entered without a leading ID. E.g. BR to query the baud rate***

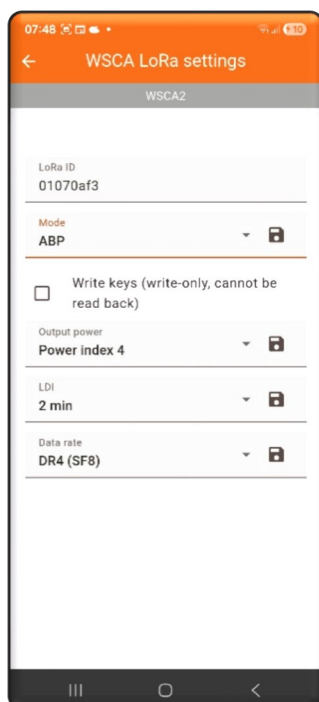

The transmission line should be set to "1 - high". It is adjusted automatically by the LoRaWAN.

The LoRaWAN parameters can be set in this dialog. The dialog shows the settings on delivery. They can be changed and saved using the floppy disk symbol.

After adjusting the settings, the settings dialog for WLAN must be opened. This dialog can be used to re-connect the cell phone to the previous WLAN.

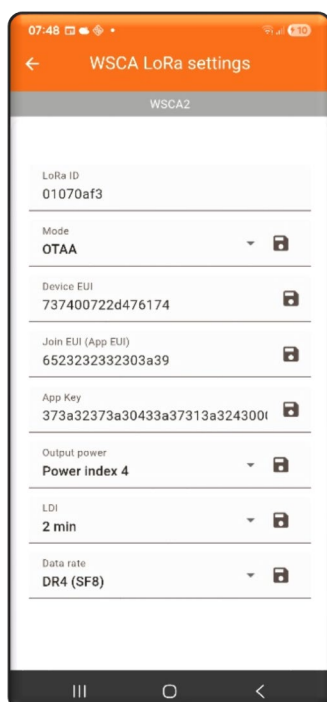

**Note:**

**The setting options in the LoRaWAN depend on the region (USA or EU). The subband must be set for devices 4.9061.1x. This setting is not possible for sensors for the EU market.**

**Furthermore LoRaWAN is dependent on data volume, transmission speed and transmission interval. Not all parameter combinations are possible and work. If, for example, too much data is to be transmitted in too short a time interval, the LoRaWAN can refuse to transmit the data.**

**An online table for defining the parameters can be found at**

**<https://avbentem.github.io/airtime-calculator/ttn/eu868/24>**

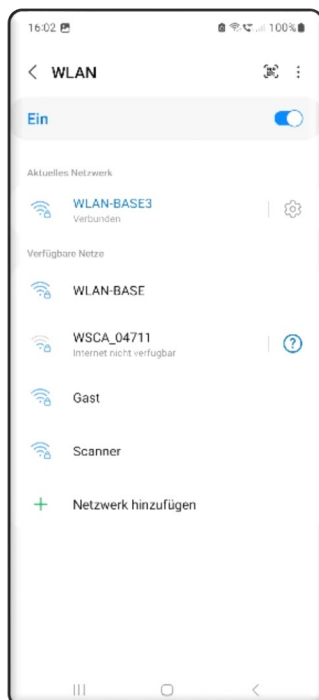

This dialog can be used to reconnect the cell phone to the previous WLAN.

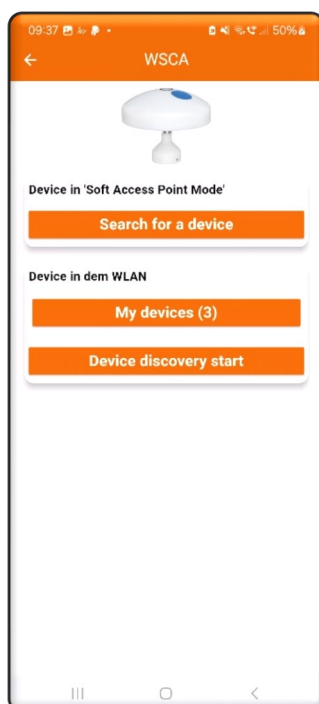

The Cumuls app does not show LoRaWAN devices in the device list because these sensors only work in "Soft-AP Mode" and are not integrated into the local WLAN.

The LoRaWan connection can be checked by "Search for a device" again and setting the mobile phone to the Soft-AP Mode of the sensor (see above). The communication in the LoRaWan can then be checked using the "Send data" switch. Furthermore, the "Data point configuration 2" button allows to configure the data to be transmitted.

## 7.4 Configuring the WSCA via serial interface

The WSCA can be configured via the RS485 serial interface. The LCFG command and sub-commands are available for LoRaWAN.

For support with parameter settings and / or special configurations via the RS485 serial connection, our free "Device Utility Tool" Art. No. 9.1700.81.000 is available for download under the following link.

Link: <https://www.thiesclima.com/de/Download/> → in the "General" section the "Thies Device Utility" program.

Command: LCFG [get/set]

Returns: LoRa settings in the form "key=value"

Example: 00LCFG

```
!00LCFG devaddr=00f78b6b; pwridx=1;
```

The following commands are available for configuring the LoRaWan:

LCFG	Display of the Lora configuration
LCFG devaddr	Display of the device address (APB-Mode)
LCFG nwskey	Network key (APB-Mode)
LCFG appskey	application key (APB-Mode)
LCFG deveui	Device -EUI (OTAA-Mode)
LCFG appeui	Application oder Join-EUI (OTAA-Mode)
LCFG appkey	Application key (OTAA-Mode)
LCFG pwridx	Transmitting power
LCFG dr	Datenrate
LCFG fsb	Frequency subband (only for 4.9061.1x.xxx)
LDP	Data points to be transmitted
LDI	Data transmission interval in fixed intervals
LSD1	Sends a data packet via LoRaWan interface

### 7.4.1 LoRa end device activation

The sensor supports the ABP activation method. OTAA is currently not supported.

### 7.4.2 Data transmission with LoRaWAN

Data transmission to the LoRaWan is binary. The LDP parameter defines which data points are transmitted in the LoRa network. For further information and coding of the LDP command, see [Command LDP](#)

The data transmission interval is defined in minutes using the LDI parameter. Currently, the last valid data values are always transmitted, see also command AI 11.6.1

**Attention:**

**The number of data parameters is limited with LoRaWan. As a rule, not all parameters that can be set with LDP can be transmitted in one telegram. If the sensor error code lights up once, the data telegram may be too long.**

The device only sends "unconfirmed" data packets in the LoRaWan. This may need to be taken into account for some applications. The binary data telegram is structured as follows:

'DID""TeleID""ChannelIndex""Value""ChannelIndex""Value" ....

With

DID -> Device identifier (1 byte) The WSCA has the device identifier 01

TeleID -> Telegram identifier (1 byte) The telegram described here has the TeleID 01

Channel index: The index for the measured value, see Table 2.

Value: The measured value for the channel index. The length of the data used in the telegram depends on the measured value. The measured value is transmitted in binary form and can be 1, 2 or 4 bytes long.

The following table shows the resolution, data type, value range and the number of bytes in the telegram.

Designation	Channel index (hex)	Measuring range	Resolution	LoRa coding	
				Data type	Value range
Brightness East	00	0 ... 150 kLux	0,1 kLux	U16	0...5dch
Brightness South	01	0 ... 150 kLux	0,1 kLux	U16	0...5dch
Brightness West	02	0 ... 150 kLux	0,1 kLux	U16	0...5dch
Twilight	03	0...999 Lux	1 Lux	U16	0...3e7h
Global radiation	04	0 ... 1300 W/m <sup>2</sup>	1 W/m <sup>2</sup>	U16	0...514h
Air temperature	05	-30 ... +60 °C	0,1 °C	S16	fed4h...258h
Precipitation status	06	1 / 0 (Precipitation yes/no)	---	U8	0...1
Wind speed	07	0 ... 40 m/s	0,1 m/s	U16	0...190h
Wind direction	08	1 ... 360 °	1 °	U16	1...168h
Absolute air pressure	09	300 ... 1100 hPa	0,1 hPa	U16	bb8h...2af8h
Relative air pressure	0a	300 ... 1100 hPa	0,1 hPa	U16	bb8h...2af8h
Relative humidity	0b	0 ... 100 % rH	0,1 %	U16	0...3e8h

Absolute humidity	0c	0 ... 400 g/m <sup>3</sup>	0,01 g /m <sup>3</sup>	U16	0 ... 9c40h
Dew point temperature	0d	-30 ... +60 °C	0,1 °C	S16	fed4h...258h
Longitude	0f	-180 ... +180 °	0,000001°	S32	fb456b00h ... aba9500h
Latitude	0e	-90 ... +90 °	0,000001°	S32	fa2b580h ... 55d4a80h
Elevation (sun)	10	-90 ... +90 °	0,1 °	S16	fc7ch ... 384h
Azimuth (sun)	11	0 ... 360 °	0,1 °	U16	0 ... e10h
Sensor status	12	-	-	U32	0 ... ffff ffffh
Station height	13	-1000 ... 9000 m	1m	S16	fc18h...2328h
Weather conditions	14	Value Bit coded  Bit0 Frost Bit1 Ice Bit2 Snow Bit3 Hail	-	U8	0 ... 15
Precipitation intensity levels	15	0 no to minimal drop 1 light precipitation 2 moderate precipitation 3 heavy precipitation		U8	0... 3h
Date	F1	Tage ab 01.01.2023		U16	0 ... ffffh
Time	F2	0 ... 43200	Double seconds of the current day	U16	0 ... 43200

Table 2 : LoRa - Coding of the data values

Data types for the transmission of measured values:

- U8 unsigned byte (1byte)
- S8 signed byte (1Byte)
- U16 unsigned int (2byte)
- S16 signed int (2Byte)
- U32 unsigned long (4Byte)
- S32 signed long (4Byte)
- U64 unsigned long (8Byte)

Example: The wind speed is measured by the sensor from 0 ... 40m/s. In the LoRaWAN, the measured value is transmitted with a resolution of 0.1m/s, i.e. the value is multiplied by 10 before transmission. This results in a value range of 0 ... 400 (0 ... 190hex). The value is transmitted with 2 bytes.

Which data values are transferred?

The mean values are transferred for wind speed and wind direction. The averaging period is set by the parameter AI. The instantaneous value is used for all other measured values, i.e. the last measured value before data transmission.

The transmission interval is set with the LDI parameter.

The transmitted data telegrams are always structured in the same way. The first four characters (in the example below "0101") stand for the identification of the sensor model (1 byte) and the command sent for querying (1 byte). The first "01" therefore indicates that the telegram was sent by a WSCA.

The following byte ("01") stands for the formatting of the data telegram. It is used to be able to react to future changes in the data format.

The following characters always alternate between the channel index of a measured variable and the measured value to be transmitted for this measured variable. The character length of the measured values (payload) corresponds to the data types of the individual measured variables specified in Table 2. Which measured variables are output in the telegram is defined with the parameter LDP, see also 11.6.2111.6.21

Example of a binary data stream in hexadecimal format:

01010500dd07000408005d0a276d0b01be 0101: Sensor and telegram identifier

0500dd :Air temperature (05) Value: 22.1 °C (00dd->221 -> 22.1 °C)

070004: Wind speed (07) Value: 0.4 m/s (0004 -> 4 -> 0.4 m/s)

08005d: Wind direction (08) Value: 93 ° (005d -> 93 -> 93 °)

0a276d: relative air pressure (0a) value: 1009.3 hPa (276d -> 10093 -> 1009.3 hPa)

0b01be: rel. humidity (0b) Value: 44.6 % rel. humidity (01be -> 446 -> 44.6% rel. humidity)

### 7.4.3 Checking the data transmission

The LSD parameter and the TF2 parameter can be used to check communication in the LoRaWan.

If the 00LSD1 command is sent to the sensor, a data telegram is sent immediately via the LoRaWan interface. The result of the data transmission can be read from the flashing status LED of the sensor.

It is also possible to switch on the debug output of the sensor using the 00TF2 command. The communication message via the LoRaWan is then output via the serial interface.

Example:

00ky234

00tf2

00lsd1

Example of the return for an error:

mac tx uncncf 1 01010501010700020808ed0a26d5ff0182

no\_free\_ch

The debug function is deactivated again with the command 00TF3 or after a device restart.

### 7.4.4 Error detection

The transmitted data values have the option of displaying the error status. The transmitted data value is replaced by the error code. For example, 07FFFF is output instead of the wing speed 070004 (from the example above).

There is the following definition for this, depending on the transferred data type:

Error detection Coding LoRa:	2 byte unsigned U16 :	0xFFFF0 .... 0xFFFFF
	2 byte signed S16:	0x7FFF0 ... 0x7FFF
	1 byte unsigned U8:	0xF0 ... 0xFF

The error bits depend on the data value. The data transmission rate is 5 minutes.

### 7.4.5 Error code for LoRaWAN communication

Communication errors during data transmission to the LoRaWAN server are indicated by the built-in green LED on the bottom of the device.

- 10 short pulses (f=10Hz)
- 2s off
- Error code through n pulses (f=1Hz)
- 2s off

The error code is coded by the number of pulses:

Number of pulses	Error code	Cause of error
1	LORA_ERROR_MAC_TX	Possibly max. number of data already sent or connection is interrupted or the data telegram is too long (see LDP command)
2	LORA_ERROR_MAC_RX	Invalid data rate
3	LORA_ERROR_MAC_JOIN_ABP	Maximum number of connections exceeded
4	LORA_ERROR_GET_VER	Internal error when reading the firmware version, contact Thies
5	LORA_ERROR_GET_HWEUI	Internal error when reading the hardware version, contact Thies
6	LORA_ERROR_MAC_RESUME	Internal error when continuing communication, contact Thies
7	LORA_ERROR_MAC_SET_PWRIDX	Invalid setting for parameter pwridx
8	LORA_ERROR_MAC_SET_CLASS_C	Is set if the device address is used multiple times in the LoRaWan network.
9	LORA_ERROR_MAC_SET_ADR_ON	Internal error, contact Thies
10	LORA_ERROR_MAC_SET_DEVADDR	Internal error, the multicast application session key is invalid. Contact Thies
11	LORA_ERROR_MAC_SET_NWKSKEY	Invalid setting for parameter nmkskey
12	LORA_ERROR_MAC_SET_APPSKEY	Invalid setting for appskey parameter
13	LORA_ERROR_MAC_SET_UPCTR_0	Internal error, contact Thies
14	LORA_ERROR_MAC_SET_DNCTR_0	Internal error, contact Thies

Table 3 : LoRaWAN error code

## 8 Maintenance

---

As the appliance operates without moving parts, i.e. wear-free, only minimal servicing is required.

Depending on the location, the appliance may become dirty. Cleaning should be carried out with water and a soft cloth. Do not use any aggressive cleaning agents.

**Caution:**

***When storing, installing, dismantling, transporting or maintaining the weather station, ensure that no water penetrates into the device and plug.***

We recommend the following procedure for humidity calibration:

1. Store the device for several hours at rather low humidity values.
2. Carry out the calibration in accordance with DKD Guideline 5-8 "Calibration of hygrometers for the direct measurement of relative humidity"; procedure A1, A2, B1 or B2.
3. Also observe the adjustment time in accordance with DKD Guideline 5-8 "Calibration of hygrometers for the direct measurement of relative humidity".

## 9 Forecast data

---

By connecting the WSCA to the Thies Cloud, it is possible to transfer forecast data from the Thies Cloud to the sensor. This function must be activated in the Thies Cloud. When the service is activated, the cloud transmits the forecast data for the next 24 hours to the sensor every hour. This data can be queried via MODBUS or Thies ASCII telegram. For the structure and content of the forecast data, see MODBUS register description from address 36001 or ASCII telegrams from telegram number 400.

Forecast data can only be transmitted correctly if the sensor is connected to the Thies Cloud via WLAN and MQTT and receives valid GPS coordinates.

Furthermore, the service for transferring the forecast data must be explicitly activated by Thies in the cloud. Please contact your sales contact person for this.

The following measured values are available as forecast data:

- Wind speed
- Maximum gust of wind speed
- Wind direction
- Air temperature
- Perceived temperature
- Relative humidity
- Relative air pressure
- Degree of cloudiness
- Visibility
- Amount of precipitation

The forecast data comes from a server (WeatherKit from Apple, as of May 2024) and is calculated by weather models. Adolf Thies GmbH & Co KG does not guarantee the accuracy of the forecast data.

The data values of the forecast data always refer to the following hour. This means that for time information, e.g. 15:00, data values refer to the period from 15:00 to 15:59.

### 9.1 Forecast data in the MODBUS data set

In the MODBUS data set, the forecast data is output from register address 36001. Address 36001 contains the date of the most recent query of the forecast data, address 36003 contains the time. The date/time specification here is always the UTC time.

The forecast data for the individual hours starts at register address 36101. The first entry (from 36101) contains the forecast data from the query time +1h. The data for the second hour can be found at address 36201. 100 register addresses are reserved for each hour. The forecast data is updated once per hour. Because the transmission of the data takes a certain amount of time, the date values are set to 0 at the beginning of the transmission of the forecast data. A 0 in these values indicates that the forecast data is invalid.

## 9.2 Forecast data in the THIES command interpreter

In the THIES command interpreter, the forecast data is output from telegram number 400. This telegram outputs the date and time of the last query of the forecast data. The date/time specification here is always the UTC time. Each further telegram 401, 402...424 outputs the forecast data for the next corresponding hour (hour offset to telegram 400).

The forecast data is updated once an hour. Because the transmission of the data takes a certain amount of time, the date values are set to 0 at the beginning of the transmission of the forecast data. A 0 in these values indicates that the forecast data is invalid.

## 10 Interface

---

The interface to the weather station consists of an RS485 connection (half-duplex mode), with the following data format:

- 9600 baud (the baud rate can be set with theCommand AP\_PWD

<id>AP\_PWD <parameter><CR> Password for SoftAP mode

Access: Read / write.

Description: Specifies the password for the SoftAP mode. SoftAP mode is used to configure the WSCA using a cell phone. The WSCA uses the SoftAP mode to set up its own WLAN to which the mobile device can connect. The password is returned in encrypted form during the query. It is different from the text entered. When entering the command, a space must be entered between AP\_PWD and the actual parameter. The space is not part of the password. Spaces are permitted within the password. Umlauts Ä, Ö, Ü and ß are not permitted. The maximum length is 64 characters.

Sample: 00AP\_PWD 12345678

Initial value: 12345678

- Command BR .
- 8 data bits.
- No parity.
- 1 stop bit.
- Data in ASCII format (command interpreter: THIES).
- Data in binary format (command interpreter: MODBUS RTU).

The behaviour (configuration) of the weather station can be changed with the available commands (see **commands and description**). For the THIES type command interpreter, the measured values are queried with theCommand TR or with theCommand TT

When the weather station is started, the character string "Weather station", software version, hardware version and serial number are output.

Example:      Weather station WSCA  
                  V02.06

## 10.2 Command interpreter THIES (4.906x.xx.xx0)

This version of the weather station has the THIES command interpreter, which can be used to change the behaviour of the device. For example, the averaging periods for wind speed and wind direction can be changed.

A command has the following basic structure:

- <id><command><CR>                    (No parameter: serves to query the set parameters).
- <id><command><parameter><CR>                    (With parameter: is used to set a new parameters).

id:                Identification number ("00" to "99")  
Command:         2-character command (see command list)  
Parameter:        Parameter value with 1 to 10 digits (decimal value in ASCII format)  
<CR>:            Carriage Return (13<sub>dec</sub>; 0x0D)

Using the identification number 'id', several devices can be operated together in the bus system. To do this, each device is assigned an individual 'id' (seeCommand ID) and the automatic telegram output is switched off (seeCommand TT )

A sent command is acknowledged with a corresponding echo telegram. The echo telegram begins with a "!" followed by the id, the command and the set value. This is followed by the characters "carriage return" and "new line".

Commands can be sent either with or without parameters. If no parameter is specified, the set value is output.

Example:         00BR<CR>  
                  !00BR00005<CR>

If a command with a parameter is sent, the parameter is checked. If the parameter is valid, it is saved and specified in the "echo telegram". If the parameter is invalid, the parameter is ignored and the set value is output in the "echo telegram".

*Examples:*

00BR00005<CR>	Send command.
!00BR00005<CR>	Echo telegram (parameter valid and password OK).
00BR00004<CR>	Send command.
!00BR00005<CR>	Echo telegram (parameter valid but key incorrect).

**Note:**

**The TR command can be used to query the sensor readings. The weather station does not respond with the echo telegram, but with the requested data telegram!**

Some commands (see command list) are protected by a password to prevent unintentional parameter adjustment. This password must be sent before the actual command.

*Example: Changing the baud rate*

```
00KY234<CR>    Enable user level commands
00BR4<CR>       Set baud rate to 4800
!00BR00004<CR> Baud rate set to 4800
```

The weather station supports 3 different password levels.

- User level (password: "234").
- Calibration data level.
- Administrator level.

**Attention**

**The password-protected commands are enabled until one of the following conditions is met:**

- **Switching of the supply voltage.**
- **The command 00KY0<CR> is sent.**
- **No new command is sent for at least 120s.**

## 11 Data telegrams

---

Data is output on request using the TR command. You can choose between the following telegrams:

- Measured value telegram 1 WSC11 compatible (parameter=1)
- Measured value telegram 2 WSCA (parameter=2)
- Forecast data Parameters 400 ... 424

The calculation of the checksum, the composition of the status word and the control/separation characters used in the telegrams are listed below.

**Control character:**

CR - Carriage Return (13<sub>dec</sub>; 0x0D)  
LF - Line Feed (10<sub>dec</sub>; 0x0A)  
STX - Start of Text (2<sub>dec</sub>; 0x02)  
ETX - End of Text (3<sub>dec</sub>; 0x03)

### Separation sign:

Separation character between the individual measured values in the string is the semicolon ';'.  
 The checksum separation character is the multiplication character '\*'

The checksum separation character is the multiplication character '\*'

### Checksum:

The checksum is the XOR combination of all characters between <STX> and the byte <\*>. The asterisk serves as a separator character for the checksum and is no longer included in the checksum.

### Status:

A status word (32 bit) is available within the weather station, which provides information about the status of the weather station. The measured values are subjected to a plausibility check and displayed in the status word.

Bit number	Function	Description
Bit 0	Precipitation sensor	=1, condensation protection active.
Bit 1	Precipitation sensor	=1, drying phase of the sensor surface.
Bit 2	GPS data	=1, No valid RMC telegram received.
Bit 3	RTC data from the GPS receiver	=1, time from GPS receiver invalid.
Bit 4	ADC values	=1, values from analog-to-digital converter invalid.
Bit 5	Air pressure	=1, measured value from pressure sensor invalid.
Bit 6		Reserved.
Bit 7	Brightness East	=1, measured value from brightness sensor East invalid.
Bit 8	Brightness South	=1, measured value from brightness sensor South invalid.
Bit 9	Brightness West	=1, measured value from brightness sensor West invalid.
Bit 10	Twilight	=1, measured value of twilight invalid.
Bit 11	Global radiation	=1, measured value from global radiation sensor invalid.
Bit 12	Air temperature	=1, measured value from air temperature sensor invalid.
Bit 13	Precipitation	=1, measured value from precipitation sensor invalid.
Bit 14	Wind speed	=1, measured value from wind speed sensor invalid.
Bit 15	Wind direction	=1, measured value from wind direction sensor is invalid.
Bit 16	Humidity sensor	=1, measured values from humidity sensor invalid (relative humidity, absolute humidity, dew point temperature).
Bit 17	Watchdog reset	=1, last restart by watchdog reset.
Bit 18	EEPROM parameters	=1, internal EEPROM parameters invalid.
Bit 19	EEPROM parameters	=1, internal EEPROM parameters contain the default values.
Bit 20	New FW	=1, last restart was with new firmware.

Table 4 : Status word

## 11.1 Measured value telegram 1

The weather station responds to the command "00TR1r" with the measured value telegram. The telegram structure is shown in the following table. The telegram is compatible with the WSC11 telegram.

Position	Length	Example	Description
1	1	<STX>	Start of text character (0x02).
2	3	WSC	Designator for the Weather station.
5	1	;	Semicolon.
6	2	##	Identification number of the Weather Station Compact Advanced (WSCA).
8	1	;	Semicolon.
9	19	dd.mm.yyyy hh:mm:ss	Date and time separated by a space dd: day, mm: month, yyyy: year, hh: hour, mm: minute, ss: second.
28	1	;	Semicolon.
29	6	#####	Specification of the time format: UTC CEST MEZ UTC+xh
35	1	;	Semicolon.
36	5	###.#	Reserved.
41	1	;	Semicolon.
42	5	###.#	Brightness East (kLux).
47	1	;	Semicolon.
48	5	###.#	Brightness South (kLux).
53	1	;	Semicolon.
54	5	###.#	Brightness West (kLux).
59	1	;	Semicolon.
60	3	###	Twilight (Lux).
63	1	;	Semicolon.
64	4	####	Global radiation (W/m2).
68	1	;	Semicolon.
69	5	###.#	Air temperature (°C).
74	1	;	Semicolon.
75	1	#	Precipitation status (0: no precipitation, 1: precipitation).
76	1	;	Semicolon.
77	4	###.#	Mean value <sup>1</sup> of the wind speed (m/s).
81	1	;	Semicolon.
82	3	###	Mean value <sup>1</sup> of the wind direction (°).
85	1	;	Semicolon.
86	6	#####.#	Absolute air pressure (hPa).
92	1	;	Semicolon.
93	6	#####.#	Relative air pressure (hPa), relative to sea level.
99	1	;	Semicolon.
100	5	###.#	Enclosure internal temperature (°C).
105	1	;	Semicolon.
106	5	###.#	Relative humidity (%RH).
111	1	;	Semicolon.

Position	Length	Example	Description
112	6	###.##	Absolute humidity (g/m <sup>3</sup> ).
118	1	;	Semicolon.
119	5	###.#	Dew point temperature (°C).
124	1	;	Semicolon.
125	11	#####	Longitude (°) (GPS position) Positive sign for longitude in an easterly direction. Negative sign for longitude in westerly direction.
136	1	;	Semicolon.
137	10	#####	Latitude (°) (GPS position) Positive sign for latitudes in a northerly direction. Negative sign for latitudes to the south.
147	1	;	Semicolon.
148	5	###.#	Position of the sun, elevation or elevation angle (°) At sunrise and sunset, the elevation is 0°. Between these prominent points (i.e. during the course of the day), the elevation assumes positive values.
153	1	;	Semicolon.
154	5	###.#	Position of the sun, azimuth or cardinal point (°) The azimuth is counted positively from north to south. 0° = North ; 180° = South
159	1	;	Semicolon.
160	8	#####	32-bit sensor status in hexadecimal representation (00000000 ... FFFFFFFF).
168	1	*	Asterisk as a separator for the checksum.
169	2	##	8-bit checksum in hexadecimal representation (00 - FF). The checksum is calculated from the exclusive-or combination of all characters after the STX up to the character before the "".
171	1	<ETX>	End of text character (0x03).
172	1	<CR>	Carriage Return (0x0D).
173	1	<LF>	Line feed (line break, 0x0A).

Table 5 : Measured value telegram 1

1: The averaging interval is set with theCommand AI .

## 11.2 Measured value telegram 2

Position	Length	Example	Description
1	1	<STX>	Start of text character (0x02).
2	3	WSC	Designator for the Weather Station Compact Advanced (WSCA).
5	1	;	Semicolon.
6	2	##	Identification number of the Weather Station Compact Advanced (WSCA).
8	1	;	Semicolon.
9	19	dd.mm.yyyy hh:mm:ss	Date and time separated by a space dd: day, mm: month, yyyy: year, hh: hour, mm: minute, ss: second.
28	1	;	Semicolon.
29	6	#####	Specification of the time format: UTC CEST MEZ UTC+xh
35	1	;	Semicolon.
36	5	###.#	Brightness East (kLux).
41	1	;	Semicolon.
42	5	###.#	Brightness South (kLux).
47	1	;	Semicolon.
48	5	###.#	Brightness West (kLux).
53	1	;	Semicolon.
54	3	###	Twilight (Lux).
57	1	;	Semicolon.
58	4	####	Global radiation (W/m2).
62	1	;	Semicolon.
63	5	###.#	Air temperature (°C).
68	1	;	Semicolon.
69	1	#	Precipitation status (0: no precipitation, 1: precipitation).
70	1	;	Semicolon.
71	2	#	Weather conditions (value Bit coded)  Bit0 Frost Bit1 Ice Bit2 Snow Bit3 Hail
73	1	;	Semicolon.
74	1	#	Precipitation intensity levels 0 no to minimal drop 1 light precipitation 2 moderate precipitation 3 heavy precipitation
75	1	;	Semicolon.
76	4	###.#	Mean value <sup>1</sup> of the wind speed (m/s).
80	1	;	Semicolon.
81	3	###	Mean value <sup>1</sup> of the wind direction (°).
84	1	;	Semicolon.

Position	Length	Example	Description
85	6	####.#	Absolute air pressure (hPa).
91	1	;	Semicolon.
92	6	####.#	Relative air pressure (hPa), relative to sea level.
98	1	;	Semicolon.
99	5	###.#	Enclosure internal temperature (°C).
104	1	;	Semicolon.
105	5	###.#	Relative humidity (%RH).
110	1	;	Semicolon.
111	6	###.##	Absolute humidity (g/m³).
117	1	;	Semicolon.
118	5	###.#	Dew point temperature (°C).
123	1	;	Semicolon.
124	11	####.#####	Longitude (°) (GPS position) Positive sign for longitude in an easterly direction. Negative sign for longitude in westerly direction.
135	1	;	Semicolon.
136	10	###.#####	Latitude (°) (GPS position) Positive sign for latitudes in a northerly direction. Negative sign for latitudes to the south.
146	1	;	Semicolon.
147	6	####.#	Altitude of the weather station relative to sea level in meters derived from the GPS data (geoid model).
153	1	;	Semicolon.
154	5	###.#	Position of the sun, elevation or elevation angle (°) At sunrise and sunset, the elevation is 0°. Between these prominent points (i.e. during the course of the day), the elevation assumes positive values.
159	1	;	Semicolon.
160	5	###.#	Position of the sun, azimuth or cardinal point (°) The azimuth is counted positively from north to south. 0° = North ; 180° = South
165	1	;	Semicolon.
166	8	#####	32-bit sensor status in hexadecimal representation (00000000 ... FFFFFFFF).
174	1	*	Asterisk as a separator for the checksum.
175	2	##	8-bit checksum in hexadecimal representation (00 - FF). The checksum is calculated from the exclusive-or combination of all characters after the STX up to the character before the ""*".
177	1	<ETX>	End of text character (0x03).
178	1	<CR>	Carriage Return (0x0D).
179	1	<LF>	Line feed (line break, 0x0A).

Table 6 : Measured value telegram 2

## Measured values

With the exception of wind speed and wind direction, the measured values are 1-second averages.

### 11.3 Measured value telegram 400

Date Time of the last forecast data. The date and time have the value 0 if the forecast data is invalid. All date/time information is output in UTC time.

Position	Length	Example	Description
1	1	<STX>	Start of text character (0x02).
2	2	01	Time offset for forecast data (time offset depends on the telegram number).
4	1	;	Semicolon.
5	10	dd.mm.yyyy	Date and time separated by a space dd: day, mm: month, yyyy: year,
15	1	;	Semicolon.
16	8	hh:mm:ss	Time hh: hour, mm: minute, ss: second.
24	1	*	Asterisk as a separator for the checksum.
25	2	##	8-bit checksum in hexadecimal representation (00 - FF). The checksum is calculated from the exclusive-or combination of all characters after the STX up to the character before the "*".
27	1	<ETX>	End of text character (0x03).
28	1	<CR>	Carriage Return (0x0D).
29	1	<LF>	Line feed (line break, 0x0A).

Table 7 : Telegram 400

## 11.4 Forecast data telegram 401 ... 424

Telegram of the forecast data. The telegram number defines the time offset of the forecast data to the time in telegram 400. Example: Telegram 403 -> Outputs the forecast data for the time 3 hours after the time stamp of telegram 400. All date/time information will be in UTC time.

Position	Length	Example	Description
1	1	<STX>	Start of text character (0x02).
2	2	01	Time offset for forecast data (time offset depends on the telegram number).
4	1	;	Semicolon.
5	10	dd.mm.yyyy	Date dd: day, mm: month, yyyy: year.
15	1	;	Semicolon.
16	8	hh:mm:ss	Time hh: hour, mm: minute, ss: second.
24	1	;	Semicolon.
25	4	##.#	Wind speed [m/s].
29	1	;	Semicolon.
30	4	##.#	Max. gust of wind speed [m/s].
34	1	;	Semicolon.
35	3	###	Wind direction [°].
38	1	;	Semicolon.
39	5	###.#	Air temperature [°C].
44	1	;	Semicolon.
45	5	###.#	Perceived temperature [°C].
50	1	;	Semicolon.
51	5	###.#	Relative humidity [% r.h.].
55	1	;	Semicolon.
56	6	#####	Relative (reduced) air pressure [hPa].
62	1	;	Semicolon.
63	3	###	Degree of cloudiness [%].
66	1	;	Semicolon.
67	5	#####	Visibility [m].
72	1	;	Semicolon.
73	4	##.#	Amount of precipitation [mm].
77	1	*	Asterisk as a separator for the checksum.
78	2	##	8-bit checksum in hexadecimal representation (00 - FF). The checksum is calculated from the exclusive-or combination of all characters after the STX up to the character before the "*".
79	1	<ETX>	End of text character (0x03).
80	1	<CR>	Carriage Return (0x0D).
81	1	<LF>	Line feed (line break, 0x0A).

Table 8 : Telegram 401 ... 424

## 11.5 Command interpreter MODBUS RTU (4.906x.xx.xx1)

With this device variant, the transmitted bytes are interpreted according to the MODBUS specification (<http://www.modbus.org/>). The weather station represents a MODBUS slave.

Data is transmitted in packets, known as frames, of a maximum of 256 bytes. Each packet contains a 16-bit CRC checksum (initial value: 0xffff).

Slave address	Function code	Data	CRC	
1byte	1byte	0...252Byte(s)	2Bytes	
			CRC low byte	CRC high byte

Table 9 : MODBUS Frame

The following MODBUS functions are supported:

- 0x04 (Read Input Register).
- 0x03 (Read Holding Registers).
- 0x06 (Write Single Register).
- 0x10 (Write Multiple Registers).

The weather station supports write access for slave address 0 ("Broadcast").

All MODBUS requests received are checked for validity before execution. In the event of an error, the weather station responds with one of the following exceptions (→ MODBUS Exception Responses).

Code	Name	Meaning
0x01	ILLEGAL FUNCTION	The function code in the request is not permitted for the register address.
0x02	ILLEGAL DATA ADDRESS	The register address in the request is not valid.
0x03	ILLEGAL DATA VALUE	The data specified in the request is not permitted.

Table 10 : MODBUS Exceptions.

### 11.5.1 Measured values (input register)

All measured values of the weather station occupy 32 bits, i.e. 2 MODBUS register addresses. The following table shows the assignment of measured value to register address, whereby the measured values are sorted as follows:

- By measured value type (30001 to 34999).
- In complete sequence (35001 to 39999).

Register address	Parameter name	Unit	Multiplier	Explanation	Data type
30001	Wind speed	m/s	10	Value / 10 (1 decimal place, e.g. 101=10.1m/s)	U32
30003	Average wind speed	m/s	10	Value / 10 (1 decimal place, e.g. 101=10.1m/s)	U32
30201	Wind direction	°	10	Value / 10 (1 decimal place, e.g. 1010=101.0°)	U32
30203	Mean value Wind direction	°	10	Value / 10 (1 decimal place, e.g. 1010=101.0°)	U32
30401	Air temperature	°C	10	Value / 10 (1 decimal place, e.g. 255=25.5°C)	S32
30403	Internal housing temperature	°C	10	Value / 10 (1 decimal place, e.g. 355=35.5°C)	S32
30601	Relative humidity	%r.H.	10	Value / 10 (1 decimal place, e.g. 355=35.5°r.H.)	U32
30603	Absolute humidity	g/m <sup>3</sup>	100	Value / 100 (2 decimal places, e.g. 923=9.23g/m <sup>3</sup> )	U32
30605	Dew point temperature	°C	10	Value / 10 (1 decimal place, e.g. 115=11.5°C)	S32
30801	Absolute air pressure	hPa	100	Value / 100 (2 decimal places, e.g. 105000=1050.00hPa)	U32
30803	Relative air pressure referred to NHN	hPa	100	Value / 100 (2 decimal places, e.g. 105000=1050.00hPa)	U32
31001	Global radiation	W/m <sup>2</sup>	10	Value / 10 (1 decimal place, e.g. 10000=1000.0W/m <sup>2</sup> )	S32
31203	Brightness East	kLux	10	Value / 10 (1 decimal place, e.g. 1200=120.0kLux)	U32
31205	Brightness South	kLux	10	Value / 10 (1 decimal place, e.g. 1200=120.0kLux)	U32
31207	Brightness West	kLux	10	Value / 10 (1 decimal place, e.g. 1200=120.0kLux)	U32

Register address	Parameter name	Unit	Multiplier	Explanation	Data type
31209	Twilight	Lux	1	Value (no decimal place, e.g. 500=500Lux)	U32
31401	Precipitation status		1	Value (no decimal place, (0=no precipitation, 1=precipitation))	U32
31413	Weather condition		1	Value Bit coded  Bit0 Frost Bit1 Ice Bit2 Snow Bit3 Hail	U32
31415	Precipitation intensity levels	-	1	1 no to minimal drop 2 light precipitation 3 moderate precipitation 4 heavy precipitation	U32
34601	Date		1	Value (no decimal place, YYYYMMDD, e.g. 20121210=10.12.2012)	U32
34603	Time		1	Value (no decimal place, HHMMSS, e.g. 121035=12:10:35)	U32
34605	Time format	h	1	Value (no decimal place, offset to UTC in hours, e.g. 1=UTC+1h)	S32
34801	Longitude	°	1000000	Value / 1000000 (6 decimal places, e.g.)	S32
34803	Latitude	°	1000000	Value / 1000000 (6 decimal places, e.g.)	S32
34805	Position of the sun Elevation	°	10	Value / 10 (1 decimal place, e.g. 900=90.0°)	S32
34807	Position of the sun Azimuth	°	10	Value / 10 (1 decimal place, e.g. 1800=180.0° / 0°=north, 180°=south, clockwise 0...360°)	S32
34809	Height above sea level	m	1	Value (no decimal place, e.g. 240=240m above sea level)	U32
34811	Sensor status		1	Value (no decimal place, bit coded, depending on sensor)	U32
34813	Reserved	-	-	-	U32
34815	Operating time	s	1	Value (no decimal place, e.g. 255=255s)	U32
34817	Mean value of the height above sea level received via GPS	m	10	Value (1 decimal place, e.g. 240=24.0m above sea level)	U32
35001	Wind speed (30001) <sup>1</sup>	m/s	10	Value / 10	U32

Register address	Parameter name	Unit	Multiplier	Explanation	Data type
				(1 decimal place, e.g. 101=10.1m/s)	
35003	Average wind speed (30003) <sup>1</sup>	m/s	10	Value / 10 (1 decimal place, e.g. 101=10.1m/s)	U32
35005	Wind direction (30201) <sup>1</sup>	°	10	Value / 10 (1 decimal place, e.g. 1010=101.0°)	U32
35007	Mean value Wind direction (30203) <sup>1</sup>	°	10	Value / 10 (1 decimal place, e.g. 1010=101.0°)	U32
35009	Air temperature (30401) <sup>1</sup>	°C	10	Value / 10 (1 decimal place, e.g. 255=25.5°C)	S32
35011	Internal housing temperature (30403) <sup>1</sup>	°C	10	Value / 10 (1 decimal place, e.g. 355=35.5°C)	S32
35013	Dew point temperature (30605) <sup>1</sup>	°C	10	Value / 10 (1 decimal place, e.g. 115=11.5°C)	S32
35015	Rel. humidity (30601) <sup>1</sup>	%r.H.	10	Value / 10 (1 decimal place, e.g. 355=35.5°r.H.)	U32
35017	Abs. humidity (30603) <sup>1</sup>	g/m <sup>3</sup>	100	Value / 100 (2 decimal places, e.g. 923=9.23g/m <sup>3</sup> )	U32
35019	Absolute air pressure (30801) <sup>1</sup>	hPa	100	Value / 100 (2 decimal places, e.g. 105000=1050.00hPa)	U32
35021	Relative air pressure in relation to Sea level (30803) <sup>1</sup>	hPa	100	Value / 100 (2 decimal places, e.g. 105000=1050.00hPa)	U32
35023	Global radiation (31001) <sup>1</sup>	W/m <sup>2</sup>	10	Value / 10 (1 decimal place, e.g. 10000=1000.0W/m <sup>2</sup> )	S32
35025	Reserved	-	-	-	U32
35027	Brightness East (31203) <sup>1</sup>	kLux	10	Value / 10 (1 decimal place, e.g. 1200=120.0kLux)	U32
35029	Brightness South (31205) <sup>1</sup>	kLux	10	Value / 10 (1 decimal place, e.g. 1200=120.0kLux)	U32
35031	Brightness West (31207) <sup>1</sup>	kLux	10	Value / 10 (1 decimal place, e.g. 1200=120.0kLux)	U32
35033	Twilight (31209) <sup>1</sup>	Lux	1	Value (no decimal place, e.g. 500=500Lux)	U32
35035	Precipitation status (31401) <sup>1</sup>		1	Value (no decimal place, (0=no precipitation, 1=precipitation))	U32
35037	Date (34601) <sup>1</sup>		1	Value (no decimal place, YYYYMMDD, e.g. 20121210=10.12.2012)	U32
35039	Time		1	Value	U32

Register address	Parameter name	Unit	Multiplier	Explanation	Data type
	(34603) <sup>1</sup>			(no decimal place, HHMMSS, e.g. 121035=12:10:35)	
35041	Time format (34605) <sup>1</sup>	h	1	Value (no decimal place, offset to UTC in hours, e.g. 1=UTC+1h)	S32
35043	Longitude (34801) <sup>1</sup>	°	1000000	Value / 1000000 (6 decimal places, e.g.)	S32
35045	Latitude (34803) <sup>1</sup>	°	1000000	Value / 1000000 (6 decimal places, e.g.)	S32
35047	Position of the sun Elevation (34805) <sup>1</sup>	°	10	Value / 10 (1 decimal place, e.g. 900=90.0°)	S32
35049	Position of the sun Azimuth (34807) <sup>1</sup>	°	10	Value / 10 (1 decimal place, e.g. 1800=180.0° / 0°=north, 180°=south, clockwise 0...360°)	S32
35051	Height above sea level (34809) <sup>1</sup>	m	1	Value (no decimal place, e.g. 240=240m above sea level)	U32
35053	Sensor status (34811) <sup>1</sup>		1	Value (no decimal place, bit coded, depending on sensor)	U32
35055	Reserved	-	-	-	U32
35057	Reserved	-	-	-	U32
35059	Reserved	-	-	-	U32
35061	Operating time	s	1	Value (no decimal place, e.g. 24000=24000s since last reset)	U32
35063	Mean value of the height above sea level received via GPS (34817) <sup>1</sup>	m	10	Value (1 decimal place, e.g. 240=24.0m above sea level)	U32
35065	Reserved	-	-	-	U32
35067	Reserved	-	-	-	U32
35069	Reserved	-	-	-	U32
35071	Weather condition (31413) <sup>1</sup>		1	Value Bit coded  Bit0 Frost Bit1 Ice Bit2 Snow Bit3 Hail	U32
35073	Precipitation intensity levels (31415) <sup>1</sup>	-	1	1 no to minimal drop 2 light precipitation 3 moderate precipitation 4 heavy precipitation	U32
<b>Date/time of program query</b>					
36001	Date of the current forecast request (UTC)		1	Value (no decimal place, YYYYMMDD, e.g. 20121210=10.12.2012)	U32
36003	Time of the current forecast request (UTC)		1	Value (no decimal place, HHMMSS, e.g. 121035=12:10:35)	U32

Register address	Parameter name	Unit	Multiplier	Explanation	Data type
Forecast data +1h					
36101	Date of forecast data set		1	Value (no decimal place, YYYYMMDD, e.g. 20121210=10.12.2012)	U32
36103	Time forecast record		1	Value (no decimal place, HHMMSS, e.g. 121035=12:10:35)	U32
36105	Wind speed	m/s	10	Value / 10 (1 decimal place, e.g. 101=10.1m/s)	U32
36107	Wind speed gust	m/s	10	Value / 10 (1 decimal place, e.g. 101=10.1m/s)	U32
36109	Wind direction	°	10	Value / 10 (no decimal place, e.g. 101=101°)	U32
36111	Air temperature	°C	10	Value / 10 (1 decimal place, e.g. 255=25.5°C)	S32
36113	Perceived temperature	°C	10	Value / 10 (1 decimal place, e.g. 255=25.5°C)	S32
36115	Relative humidity	%r.H.	10	Value / 10 (1 decimal place, e.g. 355=35.5°r.H.)	U32
36117	Relative air pressure referred to NHN	hPa	100	Value / 100 (1 decimal place, e.g. 10500=1050.0hPa)	U32
36119	Degree of cloudiness	%	10	Value / 10 (no decimal place, e.g. 35=35%)	U32
36121	Visibility	m	1	Value (no decimal place, e.g. 240=240m)	U32
36123	Amount of precipitation	mm	10	Value / 10 (1 decimal place, e.g. 102=10.2mm)	U32
36201...36223 Forecast data +2h 36301...36323 Forecast data +3h 36401...36423 Forecast data +4h 36501...36523 Forecast data +5h 36601...36623 Forecast data +6h 36701...36723 Forecast data +7h 36801...36823 Forecast data +8h 36901...36923 Forecast data +9h 37001...37023 Forecast data +10h 37101...37123 Forecast data +11h 37201...37223 Forecast data +12h 37301...37323 Forecast data +13h 37401...37423 Forecast data +14h 37501...37523 Forecast data +15h 37601...37623 Forecast data +16h 37701...37723 Forecast data +17h 37801...37823 Forecast data +18h 37901...37923 Forecast data +19h 38001...38023 Forecast data +20h 38101...38123 Forecast data +21h					

Register address	Parameter name	Unit	Multiplier	Explanation	Data type
38201...38223	Forecast data +22h				
38301...38323	Forecast data +23h				
Forecast data +24h					
38401	Date Forecast data set		1	Value (no decimal place, YYYYMMDD, e.g. 20121210=10.12.2012)	U32
38403	Time forecast data set		1	Value (no decimal place, HHMMSS, e.g. 121035=12:10:35)	U32
38405	Wind speed	m/s	10	Value / 10 (1 decimal place, e.g. 101=10.1m/s)	U32
38407	Wind speed gust	m/s	10	Value / 10 (1 decimal place, e.g. 101=10.1m/s)	U32
38409	Wind direction	°	10	Value / 10 (no decimal place, e.g. 101=101°)	U32
38411	Air temperature	°C	10	Value / 10 (1 decimal place, e.g. 255=25.5°C)	S32
38413	Perceived temperature	°C	10	Value / 10 (1 decimal place, e.g. 255=25.5°C)	S32
38415	Relative humidity	%r.H.	10	Value / 10 (1 decimal place, e.g. 355=35.5°r.H.)	U32
38417	Relative air pressure referred to NHN	hPa	100	Value / 100 (1 decimal place, e.g. 1050.0=1050.0hPa)	U32
38419	Degree of cloudiness	%	10	Value / 10 (no decimal place, e.g. 35=35%)	U32
38421	Visibility	m	1	Value (no decimal place, e.g. 240=240m)	U32
38423	Amount of precipitation	mm	10	Value / 10 (1 decimal place, e.g. 102=10.2mm)	U32

Table11 : MODBUS Input Register

<sup>1</sup>: The numbers in brackets indicate the register addresses that represent the same measured values. For example, the wind speed, for example, is at address 30001 and at address 35001.

**Note**

**The MODBUS master can read out all measured values with one request due to the gapless arrangement of the measured values from address 35001!**

## 11.5.2 Commands (Holding Register)

All commands of the Weather Station Compact Advanced (WSCA) occupy 32 bits, i.e. 2 MODBUS register addresses and represent unsigned integers. The following example shows how to change the baud rate to 19200 baud.

1. Set password for the user level (KY=234)

Slave address	Function code	Start address	Number of registers	Number of byte(s)	Data	CRC	
0x01	0x10	0x9C 49	0x00 02	0x04	0x00 00 00 EA	0x4F 7C	
						CRC low byte	CRC high byte

2. Command Set baud rate to 19200 baud (BR=6)

Slave address	Function code	Start address	Number of registers	Number of byte(s)	Data	CRC	
0x01	0x10	0x9C 45	0x00 02	0x04	0x00 00 00 06	0x4E A4	
						CRC low byte	CRC high byte

## 11.6 Commands and description

The following table shows the available commands and the associated passwords for reading and writing:

Command	Initial value Factory setting	MODBUS Register address	Description	password Read <sup>1</sup> / Write <sup>2</sup>	
Command AI	10	40069	Averaging interval for wind direction and wind speed	Without	Users
AP_PWD	12345678	-	Password for SoftAP mode	Without	Users
BR	96	40005	Select the baud rate	Without	Users
CI	0	40013	Command interpreter	Without	Users
DC	0	40081	Calculation type for twilight	Without	Users
Command DO	0	40037	North correction of the wind direction	Without	Users
Command FB	1	40001	Quick start mode	Without	Users
Command FW	1500	40091	Sensitivity of precipitation sensor	Without	Users
Command HP	5	40035	Heating capacity Condensation protection	Without	Users

Command ID	0 (THIES) 1 (MODBUS)	40003	Identification number or slave address	Without	Users
Command KY	0	40009	Set key / password	Without	Without
Command LC	0	40045	LED control	Without	Without
LCFG	-	-	Query the LoRa information	Without	Without
LCFG appskey	001122334455 66778899aabb ccddeeff	-	LoRaWan appskey	Not readable	Users
LCFG devaddr	-	-	LoRaWan device address	Not readable	Users
LCFG nwkskey	001122334455 66778899aabb ccddeeff	-	LoRaWan network key	Not readable	Users
LCFG pwridx	1	-	LoRaWan transmission power	Without	Users
LCFG dr	0	-	LoRa data rate	Without	Users
LCFG fsb	0	-	LoRa frequenz subband	Not readable	Users
LDI	4	40031	LoRa data transmission interval	Without	Users
LDP	1921	40029	LoRa measured values for transmission	Without	Users
LRA	-	-	Lora Communication Mode	Without	Users
LL	-	-	Read out the system information	Without	Without
LSD	-	-	Immediate transmission of data via the LoRaWan, only with device variant 4.9061.00.xxx	Without	Without
MQ_Thies	1	40051	Use of the Thies MQTT server	Without	Users
MQ_ACT	1	40049	Use of MQTT	Without	Users
MQ_Name	-	-	Name of the MQTT server	Without	Users
MQ_USER	-	-	User name for the MQTT server	Without	Users
MQ_PW	-	-	Password for the MQTT server	Without	Users
MQ_Port	-	-	Port for the MQTT server	Without	Users
RD		40023	Response Delay	Without	Users
RS	-	40021	Reset	Without	Users
Command SF	0	40075	Frame format	Without	Users
Command SH	0	40071	Station height	Without	Users
Command SV	-	45005	SW version	Without	-
Command TR	-	-	Telegram query	Without	Without
Command TT	0	-	Automatic telegram output	Without	Without
Command TZ	0	40073	Time zone	Without	Users
WL_Name					
WL_PW					
XX	WSCA	-	Station name	Without	Users

Table12 : Command list

1: Command without parameter (used to read the set parameter).

2: Command with parameter (used to write a new parameter).

**Note**

**All values of the commands from Table 12 (except KY and TR) are saved in the EEPROM. The number of memory cycles is limited, memory cycles >100000 can lead to a device defect.**

### 11.6.1 Command AI

<id>AI<parameter><CR> Averaging interval for wind speed and wind direction

Access: Read / write.

Description: The AI command is used to specify the averaging interval for the wind speed and wind direction in minutes. The averaging of the wind speed is scalar and the averaging of the wind direction is vectorial.

If the parameter is 0, averaging is deactivated and the mean values correspond to the instantaneous values. The wind direction during calm conditions (< 0.6 m/s), set to 0°. Wind from the north is mapped at 360°.

Parameter description: AI = 0 → Averaging deactivated  
AI = 1 → Averaging interval equal to 1 minute

Value range: 0...10

Initial value: 10

### 11.6.2 Command AP\_PWD

<id>AP\_PWD <parameter><CR> Password for SoftAP mode

Access: Read / write.

Description: Specifies the password for the SoftAP mode. SoftAP mode is used to configure the WSCA using a cell phone. The WSCA uses the SoftAP mode to set up its own WLAN to which the mobile device can connect. The password is returned in encrypted form during the query. It is different from the text entered. When entering the command, a space must be entered between AP\_PWD and the actual parameter. The space is not part of the password. Spaces are permitted within the password. Umlauts Ä, Ö, Ü and ß are not permitted. The maximum length is 64 characters.

Sample: 00AP\_PWD 12345678

Initial value: 12345678

### 11.6.3 Command BR

<id>BR<parameter><CR> Setting the baud rate

Access: Read / write.

Description: The BR command is used to set the desired build rate.  
See also SF command.

Parameter description:

Parameters	Parameters	Description
12	2	1200baud
24	3	2400baud
48	4	4800baud
96	5	9600baud
192	6	19200baud
384	7	38400baud
576	8	57600baud
1152	9	115200baud

Value range: 12 / 24 / 48 / 96 / 192 / 384 / 576 / 1152

Initial value: 96

### 11.6.4 Command CI

<id>CI<parameter><CR> Selection of the command interpreter

Access: Read / write.

Description: The desired command interpreter is set with the CI command.

**Note:**

*If the identification number (ID) is greater than 98, it is automatically set to 0 when switching to the THIES interpreter!*

**Note:**

*If the identification number (ID) is 0, it is not possible to switch to the MODBUS RTU interpreter!*

Parameter description:

Parameters	Description
0	THIES
1	MODBUS RTU

Value range: 0 to 1

Initial value: 0

### 11.6.5 Command DC

<id>DC<parameter><CR> Calculation type for twilight

Access: Read / write.

Description: The DC command is used to specify the calculation type for twilight. The twilight is calculated from the 4 direction-dependent brightness values. You can choose between the sum and the mean value.

Parameter description: 0: Twilight corresponds to the sum of the 3 brightness values  
1: Twilight corresponds to the average of the 3 brightness values

Value range: 0...1

Initial value: 0

### 11.6.6 Command DO

<id>DO<parameter><CR> North correction of the wind direction

Access: Read / write.

Description: The DO command is used to specify an offset for the wind direction in °. This can be used to correct the north direction.

Value range: 0...360

Initial value: 0

### 11.6.7 Command FB

<id>FB<parameter><CR> Quick start mode

Access: Read / write.

Description: The "FB" command is used to set the quick start mode.

Parameter description: 0: Quick start mode switched off  
1: Quick start mode switched on

Value range: 0...1

Initial value: 1

### 11.6.8 Command FW

<id>FW<parameter><CR> Sensitivity of precipitation sensor

Access: Read / write.

Description: Precipitation detection is capacitive, which means that the capacitance depends on the area of the sensor that is wetted with water. In the weather station, the capacitance is measured indirectly via a frequency measurement. When dry, the frequency is approx. 38 kHz and decreases with increasing wetting. If the sensor surface is completely wetted, the frequency is approx. 17kHz.

The "FW" command is used to set the sensitivity of the precipitation sensor. The value is given in ppm and indicates the threshold (frequency deviation between instantaneous value and moving average over 5s) for detecting precipitation.

Parameter description: 100: High sensitivity, i.e. even a small wetted area is recognized as precipitation  
 20000: Low sensitivity, i.e. only a large wetted area is detected as precipitation.  
 A drop with a diameter of approx. 2 mm corresponds to a change in value of approx. 380 increments.

Value range: 100...20000

Initial value: 1500

### 11.6.9 Command HP

<id>HP<parameter><CR> Heat output

Access: Read / write.

Description: The "HP" command is used to set the heating power for the condensation protection of the precipitation monitor. The value is given as a percentage.

To avoid false-positive LV outputs, the HP=20 setting is recommended for use in hot and humid climates (RF>85 % @ air temperature>35 °C)

Parameter description: 5...8: Maximum sensitivity of the precipitation monitor for detecting the smallest precipitation intensities.

9...17: High sensitivity with simultaneous reduction of sensitivity for fog, haze and dew.

18...22: Maximum insensitivity to fog, haze and condensation.

Value range: 0...100

Initial value: 5

### 11.6.10 Command ID

<id>ID<parameter><CR> identification number (Sensor ID)

Access: Read / write.

Description: This command sets the identification number (THIES interpreter) or the slave address (MODBUS RTU interpreter). A response telegram is only sent if the 'id' contained in the command matches the one set in the weather station. An exception is the generic 'id', for which all weather stations respond (THIES interpreter). After the 'id' has been changed, the device responds immediately with the new 'id'.

Parameter description: 99 generic 'id' (THIES interpreter)  
0 Broadcast slave address (MODBUS RTU interpreter)

Value range: 0 to 99 (THIES Interpreter)  
1 to 247 (MODBUS RTU interpreter)

Initial value: 0 (THIES Interpreter)  
1 (MODBUS RTU interpreter)

### 11.6.11 Command KY

<id>KY<parameter><CR> Key/password

Access: Read / write.

Description: The "KY" command is used to set the value for the key (password). The required password must be set to change parameters.

Parameter description: 0 No password  
234 Password for user level

Value range: 0 / 234

Initial value: 0

### 11.6.12 Command LC

<id>LC<parameter><CR> LED control

Access: Read / write.

Description: The "LC" command is used to specify the mode for controlling the blue LED.

Parameter description:

Parameters	Description
0	LED (blue) indicates wind speed.
1	LED (blue) is dark.

Examples:

LED blue dark: "00LC1\r"

Blue LED indicates wind speed: "00LC0\r"

Value range: 0 / 1

Initial value: 0

### 11.6.13 Command LCFG

<id> LCFG<CR> Query the LoRa information

Access: Read

Description:

The "LCFG" command is used to read out the status of the LoRaWan. The devaddr, pwridx, dr and adr are returned. The command also includes the settings for OTAA communication: Device-EUI, APP-EUI (identical to Join-EUI), and App-Key. These parameters are required to connect the sensor to the server when using the OTAA protocol.

devaddr: Device address, adjustable  
 pwridx: Transmission power, adjustable  
 dr: Data rate  
 adr: Adaptive data rate: (not adjustable, constant 0)  
 fsb: Frequency subband (only for 4.9061.1x.xxx)  
 deveui: Device EUI (for OTAA communication)  
 appeui: Application EUI. Also used as the Join EUI (for OTAA communication)  
 Appkey: Application key (for OTAA communication)

### 11.6.14 Command LCFG appskey

<id> LCFG appskey <parameter><CR>      LoRa application key

Access:                      Write.

Description:                Used in APB communication.

The "LCFG appskey" command is used to set the LoRaWan application key (LoRa application session key) (parameter is a string with 32 characters that represents 16 bytes in hexadecimal code). The key is only displayed in coded form when it is read out.

After sending, LCFG reinit must be sent to accept the parameters in the sensor.

Example:

00KY234

00LCFG appskey 00112233445566778899aabbccddeeff

!00LCFG appskey 00112233445566778899aabbccddeeff

#### **Attention:**

***The keyword appskey must be followed by a space that does not belong to the key. It is recommended to change the key during commissioning***

Value range:                16 characters Hexadecimal value

Initial value:                00112233445566778899aabbccddeeff

### 11.6.15 Command LCFG devaddr

<id> LCFG devaddr <parameter><CR>      LoRa device address

Access:                      Write.

Description:                Used in APB communication.

The LCFG devaddr command is used to set the device address of the LoRa-Wan. The device address (<parameter>) must be specified in hexadecimal with 6 characters

After sending, LCFG reinit must be sent to accept the parameters in the sensor.

Example:

00KY234

00LCFG devaddr 001122

!00LCFG dr 00001122

Value range:                Each hex digit can contain the characters '0'...'9' or 'a'...'f' or 'A'...'F'.

Initial value:                -

### 11.6.16 Command LCFG nwkskey

<id> LCFG nwkskey <parameter><CR> LoRa network key

Access: Write.

Description: Used in APB communication.

The "LCFG nwkskey" command is used to set the LoRaWan network key (LoRa network session key) (parameter is a 32-character string representing 16 bytes in hexadecimal code). The key cannot be read out.

After sending, LCFG reinit must be sent to accept the parameters in the sensor.

Example:

00KY234

00LCFG nwkskey 00112233445566778899aabbccddeeff

!00LCFG nwkskey 00112233445566778899aabbccddeeff

#### **Attention:**

**The keyword nwskey must be followed by a space that does not belong to the key. It is recommended to change the key during commissioning.**

Value range: 16 characters Hexadecimal value

Initial value: 00112233445566778899aabbccddeeff

### 11.6.17 Command: LCFG pwridx

<id> LCFG pwridx <parameter><CR> LoRa transmission power

Access: Read / write.

Description: The LCFG pwridx command is used to set the transmission line of the LoRa-Wan. The value range depends on the LoRaWan device used: After sending, LCFG reinit must be sent to accept the parameters in the sensor.

4.9061.0X.XXX 1 ... 5

4.9061.1X.XXX 5 ... 10

Example:

00LCFG pwridx 1

!00LCFG pwridx 1

Value range: 1 ... 5 (5 ... 10)

Initial value: 1

### 11.6.18 Command: LCFG dr

<id> LCFG dr <parameter><CR> LoRa data rate

Access: Write

Description:

The LCFG dr command is used to set the data rate of the LoRaWan.  
Data rate dr corresponds to the spreading factor sf  
The valid parameter value differs depending on the sensor type  
4.9061.0X.XXX:

dr 5 corresponds to the spreading factor SF7  
dr 0 corresponds to the spreading factor SF12

4.9061.1X.XXX:  
dr 3 corresponds to the spreading factor SF7  
dr 0 corresponds to the spreading factor SF10

After sending, LCFG reinit must be sent to accept the parameters in the sensor.

The value range depends on the LoRaWan device used:  
After sending, LCFG reinit must be sent to accept the parameters in the sensor.

Example:

00LCFG dr 1  
!00LCFG dr 1

Value range: 0 ... 5 (4.9061.0X.XXX)  
0 ... 3 (4.9061.1X.XXX)

Initial value: 0

### 11.6.19 Command: LCFG fsb

<id> LCFG dr <parameter><CR> LoRa data rate

Access: Write

Description: Activates the frequency sub-bands The LCFG fsb command is used to set the frequency sub-band. The parameter is only used in variant 4.9061.1X.XXX The sub-band used must match the set frequency of the remote station. The parameter is an 8-bit value in which each bit represents a sub-band. It is therefore possible to display several sub-bands simultaneously

Bit 0 Frequency sub-band 1 (902.3 ... 903.7, Channel0 to 7)

Bit 1 Frequency sub-band 2 (903.9 ... 905.3, Channel8 to 15)

Bit 2 Frequency sub-band 3 (905.5 ... 906.9, Channel16 to 23)

Bit 3 Frequency sub-band 4 (907.1 ... 908.5, Channel24 to 31)

Bit 4 Frequency sub-band 5 (908.7 ... 910.1, Channel32 to 39)

Bit 5 Frequency sub-band 6 (910.3 ... 911.7, Channel40 to 47)

Bit 6 Frequency sub-band 7 (911.9 ... 913.3, Channel48 to 55)

Bit 7 Frequency sub-band 8 (913.5 ... 914.9, Channel56 to 63)

After sending, LCFG reinit must be sent to accept the parameters in the sensor.

Example:

00LCFG sfb 1

Activates the sub-band 902,3 ...903,7 MHz

00LCFG sfb 9

Activates the frequency subbands (1) 902,3 ...903,7 MHz und (4)

907,1 ... 908,5 MHz

Value range: 0 ... 255 (4.9061.1x.xxx)

Initial value: 0

### 11.6.20 Command LDI

<id>LDI<parameter><CR> Lora data interval

Access: Read / write.

Description: Defines the time interval (in minutes) at which the data values are transmitted via the LoRaWan. When selecting the data points and the transmission interval, the user is responsible for ensuring that the available data volume is not exceeded. If this is the case, the sensor would indicate this by means of corresponding LEDs. The internal averaging time of the WSCA is independent of the LDI parameter. The current valid measured values are always transmitted at the time the data is sent.

Value for LDI	Transmission interval
0	1 min
1	2 min
2	3 min
3	4 min
4	5 min
5	6 min
6	10 min
7	12 min
8	15 min
9	20 min
10	30 min
11	1 h
12	2 h
13	3 h
14	4 h
15	6 h
16	8 h
17	12 h
18	24 h

Value range: 1 ... 18

Initial value: 4

### 11.6.21 Command LDP

<id>LDP<parameter><CR> Lora data points

Access: Read / write.

#### Description

Defines which data points are transmitted via the LoRaWan network.

The data points to be transmitted are set with the LDP parameter. The parameter must be interpreted in binary form. Each bit represents the transmission of a data value.

The data values can be viewed in chapter 7.2.2 Checking the data transmission in Table 2.

Measured value	Mask value (hexadecimal)
Air temperature	0000 0001h
Brightness East	0000 0002h
Brightness South	0000 0004h
Brightness West	0000 0008h
Global radiation	0000 0010h
Twilight	0000 0020h
Precipitation yes / no	0000 0040h
Wind speed	0000 0080h
Wind direction	0000 0100h
Reduced air pressure	0000 0200h
Rel. air humidity	0000 0400h
Dew point	0000 0800h
Sensor status	0000 1000h
Date	0000 2000h
Time	0000 4000h
Longitude	0000 8000h
Latitude	0001 0000h
Altitude	0002 0000h
Sun position azimuth	0004 0000h
Sun position Elevation	0008 0000h
Weather condition	0010 0000h
Precipitation intensity levels	0020 0000h

Table13 : LoRa mask values of the measured values for LDP command

#### **Attention:**

**The number of data parameters is limited with LoRaWan. As a rule, not all parameters that can be set with LDP can be transmitted in one telegram. If the sensor error code lights up once, the data telegram may be too long.**

Example: If, for example, the data values for air temperature, wind speed, wind direction and red. If, for example, the data values for air temperature, wind speed, wind direction and red air pressure are to be output, this results in the following value for parameter LPD:

Air temperature: 0000 0001h

WG: 0000 0080h

WR: 0000 0100h

Red. Air pressure: 0000 0200h

Rel. humidity: 0000 0400h

Resulting value for LPD: 0000 0781h = 1921decimal

This results in a command 00LDP1921

Value range: 0 / 4294967295 (FFFF FFFFh)

Initial value: 1| 80h | 0100h | 200h | 400h = 781h = 1921

### 11.6.22 Command LRA

<id>LRA<parameter><CR> LoRa Communication Mode

Access: read / write

Description: Sets the LoRa communication mode. The OTAA and APB modes are supported. Depending on which communication mode is set, different parameters must be used to register the sensor with the remote station. In APB mode, the following values must be entered in the LoRa remote station:

devaddr, nwskey, and appskey

These parameters are printed on the sensor's label and are listed in the included sensor documentation.

In OTAA mode, the following parameters are used:

Deveui, appeui (new: Join eui), and appkey.

These parameters can be read using the LCFG command. They are also included on the enclosed printout and can be viewed in the Cumulus app (Android and iOS).

Value range: 0: APB mode

1: OTAA mode

Example: 00LRA1

### 11.6.23 Command LL

<id>LL<parameter><CR>    Reading out system information  
Access:                            Read  
Description:                       Returns the system information of the sensor.  
Value range:                       -

#### Example:

00LL

Product description:                Weather Station Compact Advanced (WSCA)  
Station name:                        WSCA  
PCB version:                         510367  
Serial number:                        00007777  
HW identification:                    53313200534354393530303136343036  
MC Firmware version:                V05.20  
MC Bootloader version:              V03.05  
WLAN firmware version:              V01.72  
WLAN bootloader version:            V5.08  
LoRa module info:                    RN2483 1.0.5 Oct 31 2018 15:06:52  
WLAN Chip ID:                        3C2EF5FFFE67FFD5  
Required MC FW filename:            400082Vxxxx.hex  
Required WLAN filename:            400084Vxxxx.hex  
END

With

HW: Hardware

MC: Main controller

### 11.6.24 Command LSD

<id>LSD<parameter><CR> Lora send data

Access: Write.

Description Immediately sends a data packet via the LoRaWan interface.  
When reading the parameter, 0 is always returned.

Value range:

1	Send data packet via LoRaWan
2	Read response/status from LoRaWan communication module (in the form of a character string)
3	Read error number from LoRaWan communication module

Example

```
00LSD1
!00LSD 00001
```

```
00LSD2
!00LSD ok
```

```
01LSD3
!01LSD 010
```

**Note:**

*At least 3 seconds should elapse between sending the data with "LSD1" and querying the status with "LSD2"!*

### 11.6.1 Command MQ\_THIES

<id>MQ\_THIES<parameter><CR> Use of the Thies MQTT server

Access: Read / write

Description. Specifies whether the Thies MQTT server should be used.  
If MQTT\_THIES is set to 1, the parameters MQ\_NAME, MQ\_USER, MQ\_PW and MQ\_PORT are not used. In this case, internal default settings are used.

Parameter Description:

0	Use your own MQTT server
1	Use THIES MQTT server

Value range: 0 / 1

Initial value: 1

### 11.6.2 Command MQ\_ACT

<id>MQ\_ACT<parameter><CR> Use with MQTT

Access: Read / write

Description: Specifies whether the internal MQTT client is active. If MQ\_ACT is set to 0, no data is sent to the set MQTT server.

Parameter Description: 0 MQTT connection switched off  
1 MQTT connection switched on

Value range: 0 / 1

Initial value: 1

### 11.6.3 Command MQ\_NAME

<id>MQ\_NAME<parameter><CR> Name of the MQTT server

Access: Read / write

Description: Specifies the name (URL or Internet address) of the MQTT server used. When entering the command, a space must be entered between MQ\_NAME and the actual parameter. The space is not part of the name. Spaces are permitted within the name. Umlauts Ä, Ö, Ü and ß are not permitted. The maximum length is 64 characters.

Value range: Text

### 11.6.4 Command MQ\_USER

<id>MQ\_USER<parameter><CR> User name for the MQTT server

Access: Read / write

Description: Specifies the user name for accessing the MQTT server. When entering the command, a space must be entered between MQ\_USER and the actual parameter. The space is not part of the name. Spaces are permitted within the name. Umlauts Ä, Ö, Ü and ß are not permitted. The maximum length is 64 chraters.

Value range: Text

### 11.6.5 Command MQ\_PW

<id>MQ\_PW<parameter><CR> Password for the MQTT server

Access: Read / write

Description: Specifies the password for accessing the MQTT server. When entering the command, a space must be entered between MQ\_PW and the actual parameter. The space character is not part of the password. Spaces are permitted within the pass word. Umlauts Ä, Ö, Ü and ß are not permitted. The maximum length is 64 characters.

Value range: Text

### 11.6.6 Command MQ\_PORT

<id>MQ\_PORT<parameter><CR> Port for the MQTT server

Access: Read / write

Description: Specifies the port for the MQTT server. The port is a numerical value between 0 ... 65535. The value depends on the MQTT server.

Value range: 0 ... 65535

### 11.6.7 Command RS

<id>RS<parameter><CR> Reset

Access: Read / write.

Description: The RS command is used to reset the microcontroller. Without specifying a parameter, the cause of the last reset is output. The output is in the form of strings (see table below), which are separated by spaces:

String	Description
PORF	Power On Reset Flag.
EXTRF	External Reset Flag.
BORF	Brownout Reset Flag.
WDRF	Watchdog Reset Flag.
PDIRF	Programming/Debug Interface Reset Flag.
SRF	Software reset flag.
SDRF	Spike Detector Reset Flag.

Parameter description: 1 Watchdog reset  
2 Software reset

Value range: 1 / 2

Initial value: -

### 11.6.8 Command RD

<id>RD<parameter><CR>	Response delay for query telegrams
Access:	Read / write.
Description:	Specifies the time in ms that the sensor delays the response after receiving a request. This is necessary because some interface converters delay the switchover between sending and receiving.
Value range:	0 ... 50
Initial value:	20

### 11.6.9 Command SF

<id>SF<parameter><CR>	Frame format												
Access:	Read / write.												
Description:	The command is used to set the frame format of the weather station.												
Parameter description:	<table> <tr> <td>0:</td> <td>8N1 (8 data bits, no parity, 1 stop bit)</td> </tr> <tr> <td>1:</td> <td>8N2 (8 data bits, no parity, 2 stop bits)</td> </tr> <tr> <td>2:</td> <td>8E1 (8 data bits, even parity, 1 stop bit)</td> </tr> <tr> <td>3:</td> <td>8E2 (8 data bits, even parity, 2 stop bits)</td> </tr> <tr> <td>4:</td> <td>8O1 (8 data bits, odd parity, 1 stop bit)</td> </tr> <tr> <td>5:</td> <td>8O2 (8 data bits, odd parity, 2 stop bits)</td> </tr> </table>	0:	8N1 (8 data bits, no parity, 1 stop bit)	1:	8N2 (8 data bits, no parity, 2 stop bits)	2:	8E1 (8 data bits, even parity, 1 stop bit)	3:	8E2 (8 data bits, even parity, 2 stop bits)	4:	8O1 (8 data bits, odd parity, 1 stop bit)	5:	8O2 (8 data bits, odd parity, 2 stop bits)
0:	8N1 (8 data bits, no parity, 1 stop bit)												
1:	8N2 (8 data bits, no parity, 2 stop bits)												
2:	8E1 (8 data bits, even parity, 1 stop bit)												
3:	8E2 (8 data bits, even parity, 2 stop bits)												
4:	8O1 (8 data bits, odd parity, 1 stop bit)												
5:	8O2 (8 data bits, odd parity, 2 stop bits)												
Value range:	0...5												
Initial value:	0												

### 11.6.10 Command SH

<id>SH<parameter><CR>	Station height				
Access:	Read / write.				
Description:	<p>The command is used to set the station altitude at the location of the weather station.</p> <p>This value is used to calculate the relative air pressure.</p> <p>The altitude is specified in meters.</p> <p>If the set parameter is 3001, the relative air pressure is calculated using the altitude from the GPS data.</p>				
Parameter description:	<p>Height above sea level in meters</p> <table> <tr> <td>0...3000:</td> <td>Station altitude in meters (basis for calculating the relative air pressure)</td> </tr> <tr> <td>3001:</td> <td>Parameter SH is ignored (the basis for calculating the relative air pressure is the altitude from the GPS data)</td> </tr> </table>	0...3000:	Station altitude in meters (basis for calculating the relative air pressure)	3001:	Parameter SH is ignored (the basis for calculating the relative air pressure is the altitude from the GPS data)
0...3000:	Station altitude in meters (basis for calculating the relative air pressure)				
3001:	Parameter SH is ignored (the basis for calculating the relative air pressure is the altitude from the GPS data)				
Value range:	0...3001				
Initial value:	0				

**Note:**

**GPS determines ellipsoidal heights above the reference ellipsoid (==>World Geodetic Systems WGS84). The ellipsoidal heights in Germany range from 36m (in Western Pomerania) to 50 meters (in the Black Forest and in the Alps) higher than the gravity-related heights (NN, HN, NHN).**

**This means that there are regional altitude errors that can be excluded by manual input. It should also be noted that the GPS altitude values can be subject to a change of up to 30m (in relation to the WGS84 ellipsoid).**

### 11.6.11 Command SV

<id>SV<CR>	SW version
Access:	Read.
Description:	The SV command can be used to read the software version number.
Parameter description:	-
Reply telegram:	-
Value range:	-
Initial value:	-

### 11.6.12 Command TR

<id>TR<parameter><CR>	Telegram output						
Access:	Read / write.						
Description:	The command triggers the one-off transmission of a telegram. The parameter specifies the telegram type.						
Parameter description:	<table> <tr> <td>1</td> <td>Measured value telegram (WSC11 compatible)</td> </tr> <tr> <td>2</td> <td>Measured value telegram WSCA</td> </tr> <tr> <td>400 ... 424</td> <td>Forecast data (can only be used with Wi-Fi connection and connection to the Thies Cloud)</td> </tr> </table>	1	Measured value telegram (WSC11 compatible)	2	Measured value telegram WSCA	400 ... 424	Forecast data (can only be used with Wi-Fi connection and connection to the Thies Cloud)
1	Measured value telegram (WSC11 compatible)						
2	Measured value telegram WSCA						
400 ... 424	Forecast data (can only be used with Wi-Fi connection and connection to the Thies Cloud)						
Reply telegram:	see <b>chapter 11</b>						
Value range:	1,2, 400 ... 424						
Initial value:	-						

### 11.6.13 Command TT

<id>TT<parameter><CR> Automatic telegram output

Access: Read / write.

Description: The TT command can be used to set the automatic telegram output (interval=1 second).

**During the first 10 seconds after starting the weather station, the automatic telegram output remains switched off.**

During this time, the user has the option of changing the TT parameter.

Parameter description:

0	Automatic telegram output is switched off
1	Measured value telegram (WSC11 compatible)
2	Measured value telegram WSCA
400 ... 424	Forecast data (can only be used with Wi-Fi connection and connection to the Thies Cloud)

Reply telegram: see **chapter 11**

Value range: 1,2, 400 ... 424

Initial value: 0

### 11.6.14 Command TZ

<id>TZ<parameter><CR> Time zone

Access: Read / write.

Description: The TZ command can be used to change the date/time output.

Parameter description:

0	UTC
23:	UTC time - 1 hour
24:	UTC time
25:	UTC time + 1 hour
48:	CEST or CET

The changeover between summer and winter time is automatic

TZ	Meaning
0	UTC
1	UTC - 23 hours
...	...
24	UTC
...	-1
47	UTC + 23 hours
48	CEST or CET

Reply telegram: -

Value range: 0...48

Initial value: 0

### 11.6.1 Command WL\_NAME

<id>WL\_NAME <parameter><CR> WLAN network name

Access: Read / write.

Description: Specifies the name of the WLAN network to be used. When entering the command, a space must be entered between WL\_NAME and the actual parameter. The space is not part of the network name. Spaces are permitted within the WLAN name. Other leading spaces are not permitted. Umlauts Ä, Ö, Ü and ß are not permitted. The maximum length is 64 characters.

If the length of the WLAN name is shorter than two characters, the SoftAP mode does not switch off.

Sample 00WL\_NAME MyWLAN network

### 11.6.2 Command WL\_PW

<id>WL\_PW <parameter><CR> WLAN password

Access: Read / write.

Description: Specifies the password of the WLAN. The password is returned in encrypted form during the query. It is different from the text entered. When entering the command, a space must be entered between WL\_PW and the actual parameter. The space is not part of the password. Spaces are permitted within the password. Umlauts Ä, Ö, Ü and ß are not permitted. The maximum length is 64 characters.

Sample: 00WL\_PW 123456

### 11.6.3 Command XX

<id>XX<parameter><CR> Station name

Access: Read / write.

Description: Command XX returns the station name  
The station name has a maximum of 5 characters

## 12 Technical data

<b>Wind speed</b>		
	Type	Thermal anemometer rotationally symmetrical
	Measuring range	0 ... 40m/s
	Resolution	0.1m/s
	Accuracy	Up to 10m/s: ±1m/s (RMS average over 360°). From 10m/s: ± 5% (RMS - average over 360°).
<b>Wind direction</b>		
	Type	Thermal anemometer
	Measuring range	1 ... 360°
	Resolution	°
	Accuracy with laminar flow	± 10°
<b>Brightness</b>		
	Type	Silicon sensor
(East, South, West)	Measuring range	0...150kLux
	Resolution	0.1kLux
	Accuracy	±3 % (± 4.5kLux)
	Spectral range	475 ... 650nm
<b>Twilight</b>		
	Type	Silicon sensor
	Measuring range	0...999Lux
	Resolution	1Lux
	Accuracy	±10Lux
<b>Global radiation</b>		
	Type	Silicon sensor
	Measuring range	0 ... 1300W/m <sup>2</sup>
	Resolution	1W/m <sup>2</sup>
	Accuracy	±10 % (± 130W/m <sup>2</sup> )
	Spectral range	350 ... 1100nm
<b>Precipitation</b>		
	Type	Ceramic, capacitance measurement Sensor surface heated
	Precipitation	yes/no
	Hail	yes/no
	Frost	yes/no
	Ice	yes/no
	Snow	yes/no
	<b>Precipitation intensity level</b>	
	1	No to minimal drop (<0.01mm per min)

	2	Light precipitation (0.01...0.04mm per min)
	3	Moderate precipitation (0.04...0.2mm per min)
	4	Heavy precipitation (0.2...0.8mm per min)
	Heating capacity, dry sensor, condensation protection	0,1W
	Heat output, wet sensor Drying phase	1,1W
<b>Temperature</b>		
	Type	PT1000
	Measuring range	-30 ... +60°C
	Resolution	0,1 °C
	Accuracy at wind speeds > 2m/s	±1 °C (-5 ...+25°C)
<b>Air pressure sensor</b>		
	Type	Piezo resistive
	Measuring range	300 ... 1100hPa
	Resolution	0.01hPa
	Accuracy	±0.5hPa @ 20°C
	Long-term stability	±0.1hPa / year
<b>Humidity sensor</b>		
	Type	CMOS capacitive
<b>Relative humidity</b>		
	Measuring range	0 ... 100% rel. humidity
	Resolution	0.1% rel. humidity
	Accuracy at wind speeds > 2m/s	±10% rel. H. @ 20°C
<b>Absolute humidity</b>		
	Measuring range	0 ... 400g/m <sup>3</sup>
	Resolution	0.01g/m <sup>3</sup>
<b>Dew point temperature</b>		
	Measuring range	-30 ... +60°C
	Resolution	0,1°C
<b>Internal housing temperature</b>		
	Type	Silicon sensor
	Measuring range	-30 ... +60°C
	Resolution	0,1°C
	Accuracy	±2°C
<b>Digital interface</b>		
	Type	RS485
	Operating mode	Half-duplex mode
	Baud rate	1200, 2400, 4800, 9600, 19200, 38400, 57600, 115200

	Data format	ASCII (command interpreter: THIES, 4.9060/1.xx.xx0) Binary (command interpreter: MODBUS RTU, 4.9060/1.xx1)
<b>Wireless WLAN</b>		2.4GHz IEEE 802.11b/g/n
	Transmission power	+16dBm
	Range	Approx. 20m in open field
	Mode	STA + SoftAP (simultaneously: station and access point mode. SoftAP mode switches off 5 minutes after restart)
	Security	WPA2 (WPA and WPA3, Personal and Open are not supported)
	Cloud	Send data to MQTT broker
<b>LoRaWAN</b>		
<b>EU market (4.9061.01.xxx)</b>	Frequency band	EU868
	Transmission frequency	868MHz
	Transmission power	+14dBm (adjustable)
	Modulation	LoRa
	Protocol	LoRaWAN v1.0.2 Class C
<b>US market (4.9061.11.xxx)</b>	Frequency band	915MHz
	Transmission power	+18.5dBm (adjustable)
	Modulation	LoRa
	Protocol	LoRaWAN v1.0.2 Class C
<b>General</b>		
	Operating voltage	18 ... 30VDC, 18 ... 28VAC
	Power consumption	200mA @ 24V (max. 0,8A AC, max. 0,5A DC)
	Ambient condition	Temperature range
		-30 ... +60°C
		Humidity range
		Non-condensing.
To avoid false-positive LV outputs, the HP=20 setting is recommended for use in hot and humid climates (RF>85 % @ air temperature>35 °C).		
GPS reception	GPS receiver with low power consumption, integrated RTC and antenna	Frequency: 1,575.42 ... 1,602MHz
	Service life of the RTC (without supply voltage)	Approx. 3 days
<b>Housing</b>	Material	PC
	Dimensions	See dimensional drawing
	Weight	0,22kg
	Protection class	IP65 in operating position
	Connection type	7-pin plug

Table 14 : Technical data

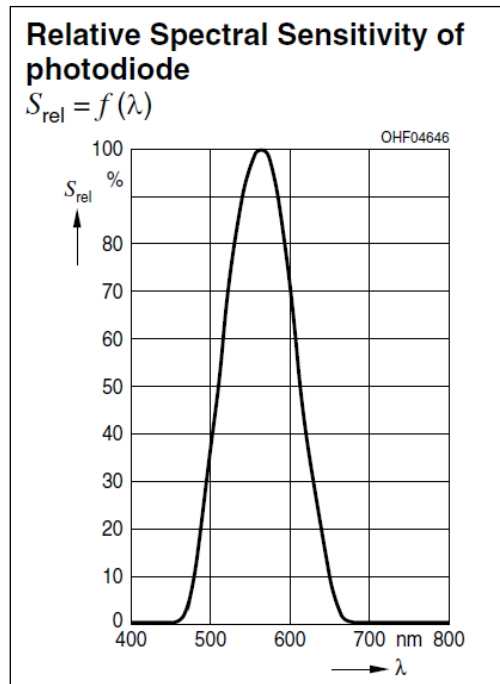

Figure 3: Spectrum of the brightness sensors

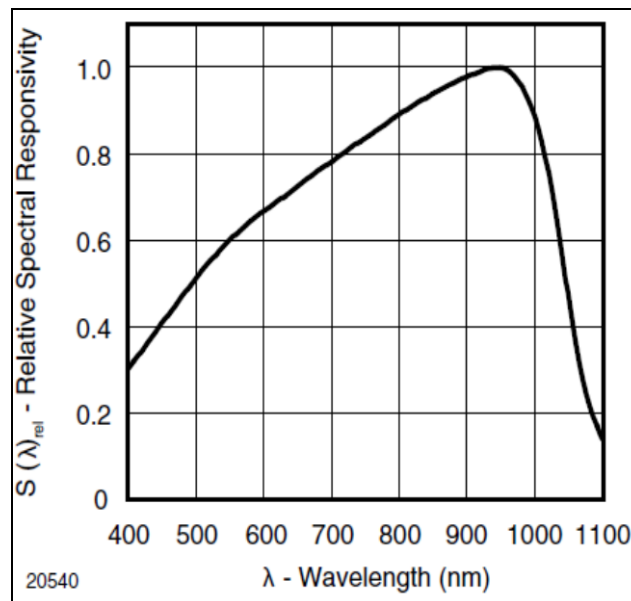
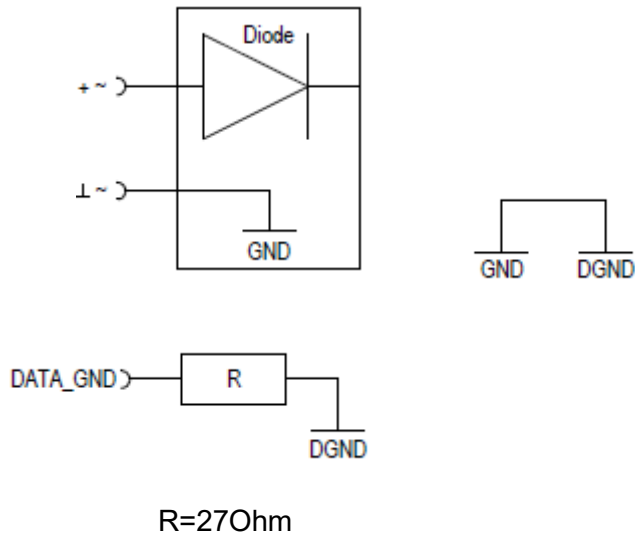

Figure 4: Spectrum for the global radiation sensor

## 13 Input circuitry

The sensor is equipped with a half-wave rectification at the input. This means that PIN 2 (DATA\_GND) and PIN 7 (-supply) have the same potential, but are decoupled via a resistor.



## 14 Dimensional drawing [in mm]

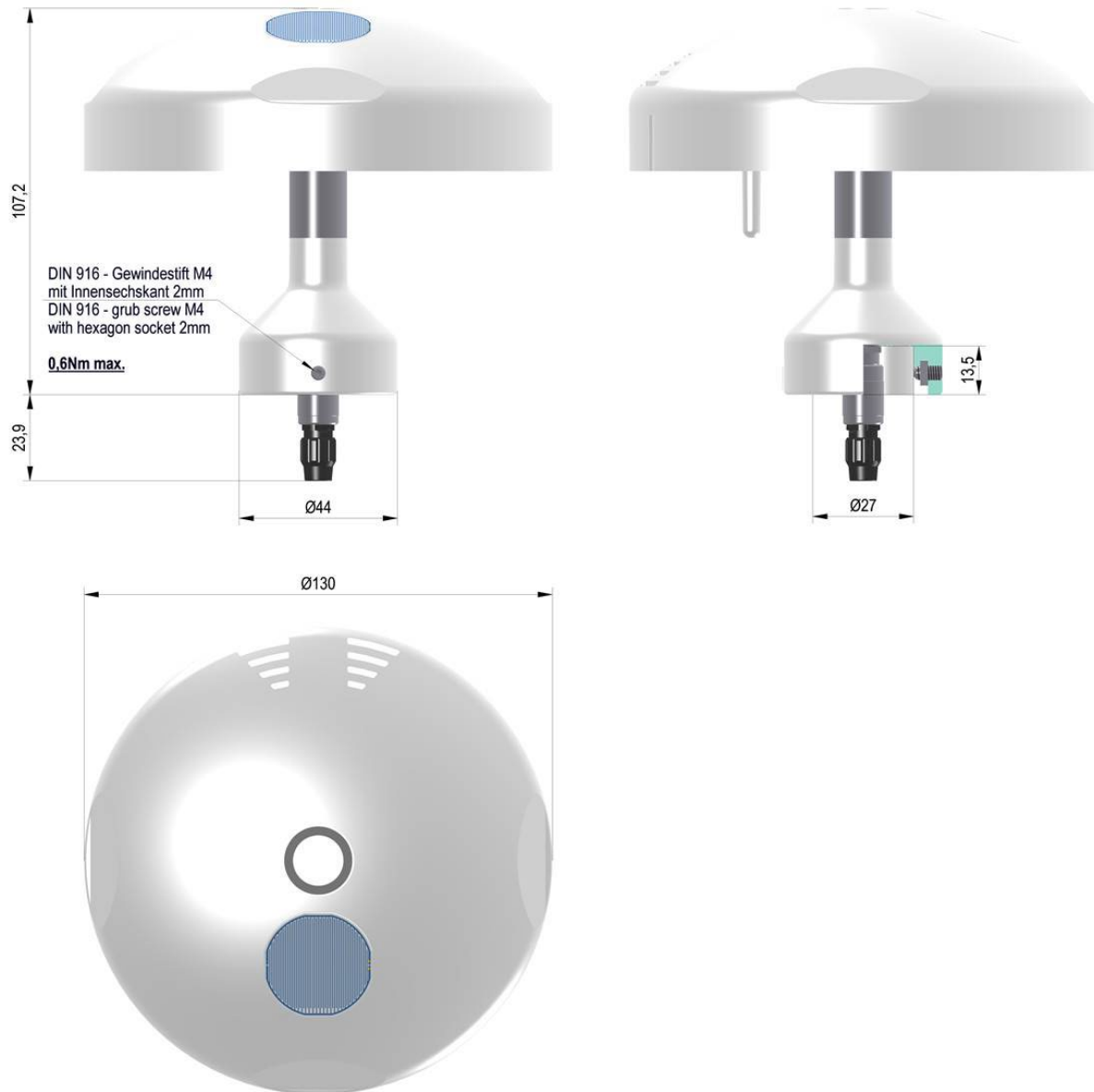

## 15 Accessories (optional)

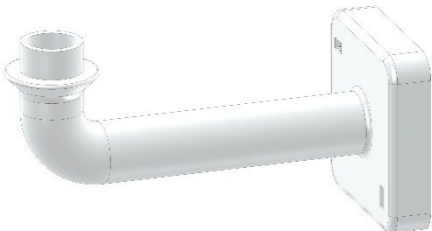
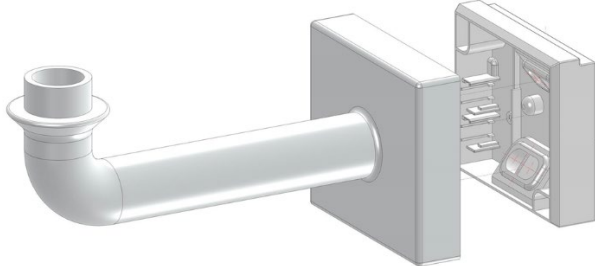
<p><b>Cables</b> Pre-assembled connection cable for Weather Station Compact Advanced (WSCA). Features: Cable with cable socket on the device side and open ends on the receiver side.</p>	<p><b>Article no.</b> <b>510023</b> <b>510024</b> <b>510197</b></p>	<p>Length: 5m 10m 20m</p>
<p><b>Wall bracket for direct wall mounting</b></p>	<p><b>510576</b></p>	
<p><b>Wall bracket with mounting plate - IP44</b></p>	<p><b>510960</b></p>	
<p><b>Pole adapter 1.5" (50mm) - 3/4" (27mm)</b></p> <p>Used to reduce the diameter of a mast tube from Ø 50mm to Ø 27mm in order to be able to mount the weather station.</p>	<p><b>510808</b></p>	<p>Dimension (outside): 90mm high</p> <p>Dimension (adaptation): Inner diameter 51mm Outer diameter 27mm</p> <p>Material: POLYCARBONATE (PC) Color: white Weight: 0,013kg</p>

		
<b>Adapter</b> WSCA for Traverse Compact	<b>Article no.</b> <b>511103</b>	Incl. hole for north orientation.
<b>Traverse</b> Compact	<b>Article no.</b> <b>4.3171.40.000</b>	Further traverses on request.
LoRaWAN gateway	<b>Article no.</b> <b>9.1704.26.000</b>	For sending LoRaWan data to the Thies Cloud.
Device Utility Tool	<b>Article no.</b> <b>9.1700.81.000</b>	Free tool for parameter settings and / or special configurations. Please send a short e-mail to <a href="mailto:info@thiesclima.com">info@thiesclima.com</a> Keyword "Utility Tool WSC 11" in the subject line, as well as your sender details and our order number / invoice number. We will then send you your log-in for download.

Table15 : Accessories

## 16 Further information / documents for download

Further information can be found in the operating instructions. This document and the short operating instructions are available for download at the following link.

Short operating instructions:

[https://www.thiesclima.com/en/db/dnl/4.906x.00.x0x\\_wsca\\_eng\\_short.pdf](https://www.thiesclima.com/en/db/dnl/4.906x.00.x0x_wsca_eng_short.pdf)

Operating instructions:

[https://www.thiesclima.com/en/db/dnl/4.906x.00.x0x\\_wsca\\_eng.pdf](https://www.thiesclima.com/en/db/dnl/4.906x.00.x0x_wsca_eng.pdf)

# 17 EC Declaration of Conformity

**Manufacturer:** Adolf Thies GmbH & Co. KG  
 Hauptstraße 76  
 37083 Göttingen, Germany  
<http://www.thiesclima.com>

**Product:** Weather Station Compact Advanced (WSCA)

Doc. Nr. 2024-45791\_CE

**Article Overview:**

4.9060.01.000      4.9060.01.001      4.9061.01.000    4.9061.11.000    4.9061.01.001    4.9061.11.001

The indicated products correspond to the essential requirement of the following European Directives and Regulations:

2014/30/EU	26.02.2014	DIRECTIVE 2014/30/EU OF THE EUROPEAN PARLIAMENT AND OF THE COUNCIL of 26 February 2014 on the harmonisation of the laws of the Member States relating to electromagnetic compatibility.
2014/35/EU	26.02.2014	DIRECTIVE 2014/35/EU OF THE EUROPEAN PARLIAMENT AND OF THE COUNCIL of 26 February 2014 on the harmonisation of the laws of the Member States relating to the making available on the market of electrical equipment designed for use within certain voltage limits.
2014/53/EU	16.04.2014	DIRECTIVE 2014/53/EU of the European Parliament and of the Council of 16 April 2014 on the harmonisation of the laws of the Member States relating to the making available on the market of radio equipment and repealing Directive 1999/5/EC Text.
2011/65/EU + 2015/863/EU + 2017/2102/EU	03.01.2013 31.03.2015 15.11.2017	DIRECTIVE (EU) 2011/65/EU + 2015/863/EU + 2017/2102, of the European Parliament and of the Council on the restriction of the use of certain hazardous substances in electrical and electronic equipment.
2012/19/EU	13.08.2012	DIRECTIVE 2012/19/EU OF THE EUROPEAN PARLIAMENT AND OF THE COUNCIL of 4 July 2012 on waste electrical and electronic equipment (WEEE).

The indicated products comply with the regulations of the directives. This is proved by the compliance with the following standards:

EN 301489-1 V 2.2.3	2019-11	ElectroMagnetic Compatibility (EMC) standard for radio equipment and services; Part 1: Common technical requirements; Harmonised Standard for ElectroMagnetic Compatibility
EN 301489-3 V 2.3.2	2023-01	ElectroMagnetic Compatibility (EMC) standard for radio equipment and services; Part 3: Specific conditions for Short-Range Devices (SRD) operating on frequencies between 9 kHz and 246 GHz; Harmonised Standard covering the essential requirements of article 3.1(b) of Directive 2014/53/EU
EN 303413 V1.1.1	2017-06	Satellite Earth Stations and Systems (SES); Global Navigation Satellite System (GNSS) receivers; Radio equipment operating in the 1 164 MHz to 1 300 MHz and 1 559 MHz to 1 610 MHz frequency bands; Harmonised Standard covering the essential requirements of article 3.2 of Directive 2014/53/EU
EN 301489-17 V 3.2.4	2020-09	ElectroMagnetic Compatibility (EMC) standard for radio equipment and services - Part 17: Specific conditions for Broadband Data Transmission Systems - Harmonised Standard for ElectroMagnetic Compatibility (Endorsement of the English version EN 301 489-17 V3.2.4 (2020-09) as a German standard)
EN 301489-19 V2.2.1	2022-09	ElectroMagnetic Compatibility (EMC) standard for radio equipment and services - Part 19: Specific conditions for Receive Only Mobile Earth Stations (ROMES) operating in the 1,5 GHz band providing data communications and GNSS receivers operating in the RNSS band (ROGNSS) providing positioning, navigation and timing data - Harmonised Standard covering the essential requirements of article 3.1(b) of Directive 2014/53/EU (Endorsement of the English version EN 301 489-19 V2.1.1 (2019-04) as a German standard)
DIN EN 55016-2-3	2020-11	Specification for radio disturbance and immunity measuring apparatus and methods - Part 2-3: Methods of measurement of disturbances and immunity - Radiated disturbance measurements (CISPR 16-2-3:2016 + A1:2019); German version EN 55016-2-3:2017 + A1:2019
DIN EN 55016-2-1	2019-11	Specification for radio disturbance and immunity measuring apparatus and methods - Part 2-1: Methods of measurement of disturbances and immunity - Conducted disturbance measurements (CISPR 16-2-1:2014 + A1:2017); German version EN 55016-2-1:2014 + A1:2017
DIN EN 55032+55032/A11	2021-03	Electromagnetic compatibility of multimedia equipment - Emission Requirements (CISPR 32:2015)
DIN EN 61000-4-2	2009-12	Electromagnetic Compatibility (EMC) - Part 4-2: Testing and measuring procedures - Testing of immunity to static electricity discharge
DIN EN 61000-4-5	2019-03	Electromagnetic compatibility (EMC) - Part 4-5: Test and measurement procedures - Testing of immunity to surge voltages
DIN EN 61000-4-6	2014-08	Electromagnetic compatibility (EMC) - Part 4-6: Test and measurement methods - Immunity to conducted disturbances, induced by high-frequency fields
DIN IEC 61000-6-2	2019-11	Electromagnetic compatibility Immunity for industrial environment
DIN EN 61000-6-3:2007 + A1:2011+2012-11+2022+06	2011-09	Electromagnetic compatibility (EMC). Generic standards. Emission standard for residential, commercial and light-industrial environments
DIN IEC 62368-1	2016-04	Audio/video, information and communication technology equipment - Part 1: Safety requirements (IEC 62368-1:2014)
DIN EN IEC 63000	2019-05	Technical documentation for the assessment of electrical and electronic products with respect to the restriction of hazardous substances.

Göttingen, 14.05.2025



General Manager - Dr. Christoph Peper



Development Manager - ppa. Jörg Peterreit

This declaration of conformity is issued under the sole responsibility of the manufacturer.

This declaration certifies the compliance with the mentioned directives, however does not include any warranty of characteristics.

Please pay attention to the security advises of the provided instructions for use.

# 18 UK-CA-Declaration of Conformity

**Manufacturer:** Adolf Thies GmbH & Co. KG  
 Hauptstraße 76  
 37083 Göttingen, Germany  
<http://www.thiesclima.com>

**Product:** Weather Station Compact Advanced (WSCA)

Doc. Nr. 2024-45791\_CA

**Article Overview:**

4.9060.01.000 4.9060.01.001 4.9061.01.000 4.9061.11.000 4.9061.01.001 4.9061.11.001

The indicated products correspond to the essential requirement of the following Directives and Regulations:

1091	08.12.2016	The Electromagnetic Compatibility Regulations 2016
1101	08.12.2016	The Electrical Equipment (Safety) Regulations 2016
1206	26.12.2017	The Radio Equipment Regulations 2017
2011/65/EU + 2015/863/EU + 2017/2102/EU	03.01.2013 31.03.2015 15.11.2017	DIRECTIVE (EU) 2011/65/EU + 2015/863/EU + 2017/2102, of the European Parliament and of the Council on the restriction of the use of certain hazardous substances in electrical and electronic equipment.
3113	01.01.2021	Regulations: waste electrical and electronic equipment (WEEE)

The indicated products comply with the regulations of the directives. This is proved by the compliance with the following standards:

EN 300 400 V 2.2.1	2017-03	Short Range Devices (SRD); Radio equipment to be used in the 1 GHz to 40 GHz frequency range; Harmonised Standard for access to radio spectrum
EN 301489-3 V 2.3.2	2023-01	ElectroMagnetic Compatibility (EMC) standard for radio equipment and services; Part 3: Specific conditions for Short-Range Devices (SRD) operating on frequencies between 9 kHz and 246 GHz; Harmonised Standard covering the essential requirements of article 3.1(b) of Directive 2014/53/EU
EN 303 413 V1.1.1	2017-06	Satellite Earth Stations and Systems (SES); Global Navigation Satellite System (GNSS) receivers; Radio equipment operating in the 1 164 MHz to 1 300 MHz and 1 559 MHz to 1 610 MHz frequency bands; Harmonised Standard covering the essential requirements of article 3.2 of Directive 2014/53/EU
EN 301489-17 V 3.2.4	2020-09	ElectroMagnetic Compatibility (EMC) standard for radio equipment and services - Part 17: Specific conditions for Broadband Data Transmission Systems - Harmonised Standard for ElectroMagnetic Compatibility (Endorsement of the English version EN 301 489-17 V3.2.4 (2020-09) as a German standard)
EN 301489-19 V2.2.1	2022-09	ElectroMagnetic Compatibility (EMC) standard for radio equipment and services - Part 19: Specific conditions for Receive Only Mobile Earth Stations (ROMES) operating in the 1,5 GHz band providing data communications and GNSS receivers operating in the RNSS band (ROGNSS) providing positioning, navigation and timing data - Harmonised Standard covering the essential requirements of article 3.1(b) of Directive 2014/53/EU (Endorsement of the English version EN 301 489-19 V2.1.1 (2019-04) as a German standard)
BS EN 55016-2-3+A2:2018-01-31	31.01.2018	Specification for radio disturbance and immunity measuring apparatus and methods. Methods of measurement of disturbances and immunity. Radiated disturbance measurements
BS EN 55016-2-1+A1:2014-07-31	31.07.2014	Specification for radio disturbance and immunity measuring apparatus and methods. Methods of measurement of disturbances and immunity. Conducted disturbance measurements
DIN EN 55032+55032/A11	2021-03	Electromagnetic compatibility of multimedia equipment. Emission Requirements
BS EN 61000-4-2	31.05.2009	Electromagnetic compatibility (EMC). Testing and measurement techniques. Electrostatic discharge immunity test
BS EN 61000-4-5+A1	30.09.2014	Electromagnetic compatibility (EMC). Testing and measurement techniques. Surge immunity test
BS EN 61000-4-6	28.02.2014	Electromagnetic compatibility (EMC). Testing and measurement techniques. Immunity to conducted disturbances, induced by radio-frequency fields
BS EN IEC 61000-6-2	25.02.2019	Electromagnetic compatibility (EMC). Generic standards. Immunity standard for industrial environments
BS EN IEC 61000-6-3	30.03.2021	Electromagnetic compatibility (EMC). Generic standards. Emission standard for equipment in residential environments
BS EN IEC 62368-1	2016-04	Audio/video, information and communication technology equipment. Safety requirements
BS EN IEC 63000	10.12.2018	Technical documentation for the assessment of electrical and electronic products with respect to the restriction of hazardous substances

Göttingen, 14.05.2025

Legally binding signature:



General Manager - Dr. Christoph Peper

Legally binding signature:



Development Manager - ppa. Jörg Peterit

This declaration of conformity is issued under the sole responsibility of the manufacturer.

This declaration certifies the compliance with the mentioned directives, however does not include any warranty of characteristics.

Please pay attention to the security advises of the provided instructions for use.

**Talk to us about your system requirements.  
We will be happy to advise you.**

**ADOLF THIES GMBH & CO. KG**

Meteorology and environmental measurement technology  
Hauptstraße 76 - 37083 Göttingen - Germany  
Phone +49 551 79001-0 - Fax +49 551 79001-65  
info@thiesclima.com

[www.thiesclima.com](http://www.thiesclima.com)

