

Weather Station Compact Advanced (WSCA)

Short - Instruction for Use

4.906x.00.00x

from software version 05/2025

MC firmware version 5.20

WLAN firmware version 1.73



Doc. No. 022089/03/26

THEWORLD OF WEATHER DATA

Safety Instructions

- Before operating with or at the device/product, read through the operating instructions. This manual contains instructions which should be followed on mounting, start-up, and operation. A non-observance might cause:
 - failure of important functions
 - endangerment of persons by electrical or mechanical effect
 - damage to objects
- Mounting, electrical connection and wiring of the device/product must be carried out only by a qualified technician who is familiar with and observes the engineering regulations, provisions and standards applicable in each case.
- Repairs and maintenance may only be carried out by trained staff or **Adolf Thies GmbH & Co. KG**. Only components and spare parts supplied and/or recommended by **Adolf Thies GmbH & Co. KG** should be used for repairs.
- Electrical devices/products must be mounted and wired only in a voltage-free state.
- **Adolf Thies GmbH & Co KG** guarantees proper functioning of the device/products provided that no modifications have been made to the mechanics, electronics or software, and that the following points are observed:
 - All information, warnings and instructions for use included in these operating instructions must be taken into account and observed as this is essential to ensure trouble-free operation and a safe condition of the measuring system / device / product.
 - The device / product is designed for a specific application as described in these operating instructions.
 - The device / product should be operated with the accessories and consumables supplied and/or recommended by **Adolf Thies GmbH & Co KG** .
 - Recommendation: As it is possible that each measuring system / device / product may, under certain conditions, and in rare cases, may also output erroneous measuring values, it is recommended using redundant systems with plausibility checks for **security-relevant applications**.

Environment

- As a longstanding manufacturer of sensors Adolf Thies GmbH & Co KG is committed to the objectives of environmental protection and is therefore willing to take back all supplied products governed by the provisions of "ElektroG" (German Electrical and Electronic Equipment Act) and to perform environmentally compatible disposal and recycling. We are prepared to take back all Thies products concerned free of charge if returned to Thies by our customers carriage-paid.
- Make sure you retain packaging for storage or transport of products. Should packaging however no longer be required, please arrange for recycling as the packaging materials are designed to be recycled.



Documentation

- © Copyright **Adolf Thies GmbH & Co KG**, Göttingen / Germany
- Although these operating instructions have been drawn up with due care, **Adolf Thies GmbH & Co KG** can accept no liability whatsoever for any technical and typographical errors or omissions in this document that might remain.
- We can accept no liability whatsoever for any losses arising from the information contained in this document.
- Subject to modification in terms of content.
- The device / product should not be passed on without the/these operating instructions.

Table of contents

1	Device versions	4
2	Installation and choice of location	5
2.1	Choice of installation location	5
2.2	Mechanical assembly	5
2.2.1	North orientation	6
2.3	Electrical installation	6
2.3.1	Cables	6
2.3.2	Wiring diagram	8
2.3.3	Connection for 5-core cable Article no. 510023 / 510024 / 510197	8
3	Commissioning MQTT / LoRaWAN	9
4	Technical data	9
5	Input circuitry	12
6	Dimensional drawing [in mm]	13
7	Further information / documents for download	13
8	EC Declaration of Conformity	13
9	UK-CA-Declaration of Conformity	15

Operating instructions

These operating instructions describe all the possible uses and settings of the appliance.

With the help of these detailed operating instructions, the user can adapt the factory settings to their needs via the serial interface or wirelessly with the WLAN of the Weather Station Compact Advanced (WSCA). The LoRaWAN interface is used for data transfer and is not designed for device parameterization.

Scope of delivery

The following parts are included in the scope of delivery:

- 1 x Weather Station Compact Advanced (WSCA)
- 1 x Mating connector for cable assembly for the sensor
- 1 x Operating instructions short version (enclosed in the package)
- 1 x Factory Settings (enclosed in the package)

The operating instructions for the WSCA can be downloaded from the following link:

https://www.thiesclima.com/en/db/dnl/4.906x.00.x0x_wsca_eng.pdf

For support with parameter settings and / or special configurations via the RS485 serial connection, our free "Device Utility Tool" Art. No. 9.1700.81.000 is available for download under the following link.

Link: <https://www.thiesclima.com/de/Download/>

In the "General" section, select the "Thies Device Utility" program.

Our free THIES-CUMULUS APP is available to support you with parameter settings and / or special configurations via wireless communication via WLAN. For more information, see [Commissioning with the Thies Cumulus app](#)

Download the APP THIES-CUMULUS at: <https://www.thiesclima.com/de/Thies-Cumulus/>

1 Device versions

Order no.	Electrical output RS485	Wireless configuration	Wireless data transmission
4.9060.01.000 ¹	Data in ASCII format (command interpreter: THIES).	WLAN ³	MQTT
4.9060.01.001 ¹	Data in binary format (command interpreter: MODBUS RTU).		
4.9061.01.000 ¹	Data in ASCII format (command interpreter: THIES).		LoRaWAN
4.9061.11.000 ²			
4.9061.01.001 ¹	Data in binary format (command interpreter: MODBUS RTU).		
4.9061.11.001 ²	Data via LoRaWAN		

¹) EU market ²) US market ³) Only WLAN networks with security level WPA2 are supported.

All versions with:

- Operating voltage 18 ... 30 VDC or 18 ... 28VAC
- Interface: RS485 half-duplex
- Measurement data can be sent to an MQTT broker

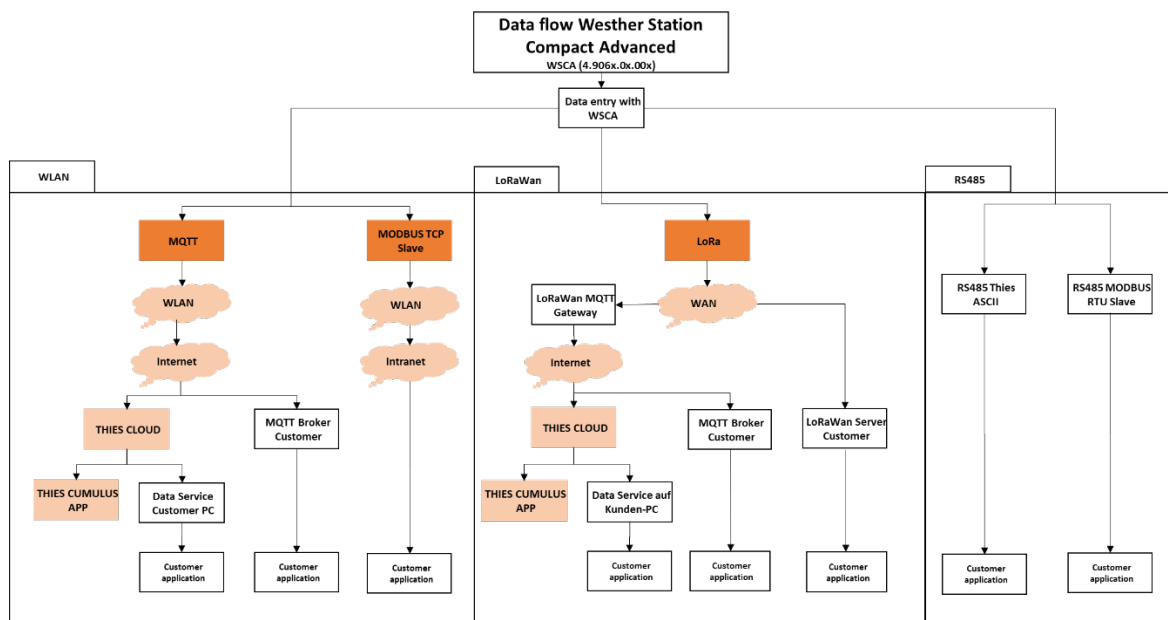

To use the device with LoRaWAN, we recommend using the LoRaWAN MQTT gateway. The gateway receives the LoRaWAN data and sends it to the Thies Cloud in MQTT format.

2 Installation and choice of location

Attention:

The Weather Station should be used in a horizontal position (plug connection at the bottom).

When installing, removing, transporting or maintaining the Weather Station, make sure that no water enters the device and plug.

2.1 Choice of installation location

An exposed location should be selected for the site. Wind shadow, light reflection and shadows must not affect the measurement properties.

Surge and lightning protection should be taken into account on site.

2.2 Mechanical assembly

The weather station installed as intended on a pipe socket / pipe with an **outer diameter of $\leq 25\text{mm}$** . The **inside diameter must be $\geq 19\text{mm}$** in order to be able to feed plugs and cables through.

Tool:

Allen key SW2mm.

Procedure:

1. Feed the cable / plug connection through the hole in the mast, tube, bracket, etc.
2. Attach the weather station to the mast, pipe.
3. Align the weather station to "North" (see chapter 4.2.1 for the procedure).
4. Secure the weather station with the M4 hexagon socket head screw.

Caution:

The hexagon socket screw must be tightened to max. 0.6Nm.

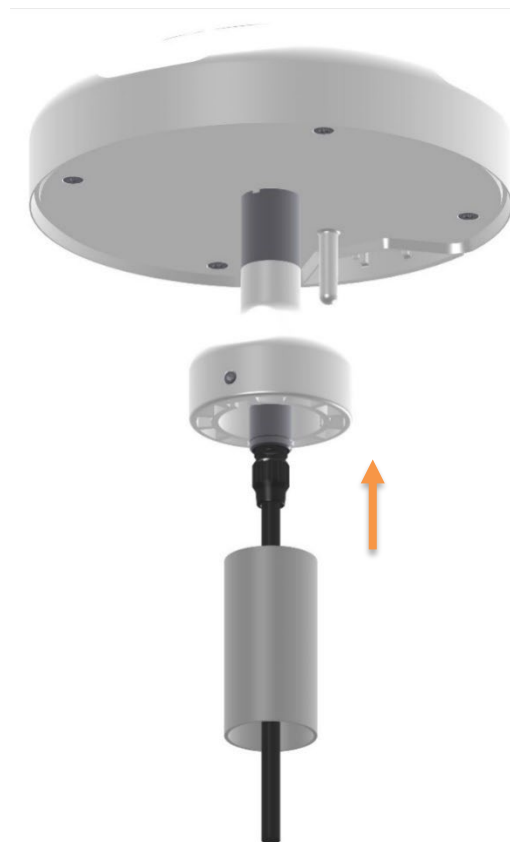

2.2.1 North orientation

The weather station must be mounted facing **north** (true north) in order to determine the exact direction of the wind and brightness.

The marking on the sensor base serves as the north marking (N)

Tool:

Allen key SW 2mm.

Procedure:

1. Locate a prominent point in the landscape (tree, building, etc.) in a northerly direction using a compass.
2. The weather station is to be aimed at the prominent point via the north marker (N) and an imaginary north-south axis.
3. Align the weather station.
The north mark (N) must point to *true north*.
4. The weather station must be secured with the M4 hexagon socket head screws if they match.



Caution:

The hexagon socket screw must be tightened to max. 0.6Nm.

Note:

When aligning to north using a compass, the misalignment (deviation of the direction of a magnetic needle from the true north direction) caused by interfering magnetic fields and magnetic field influences from iron parts and electrical cables must be taken into account.

With the help of the compact traverse adapter (article number 511103), the north alignment can be achieved by means of a hole in the adapter.

2.3 Electrical installation

The weather station is equipped with a 7-pin plug for the electrical connection. A cable socket (mating connector) is included in the scope of delivery.

2.3.1 Cables

The cable to be connected should have the following properties:

5 cores, max. 0.14mm² core cross-section, cable diameter max. 5.0mm, UV resistance, over-all shielding.

Note

A pre-assembled connection cable can be supplied as an option. Please see [Accessories \(optional\)](#)

Cable socket, type: Binder, Series 711

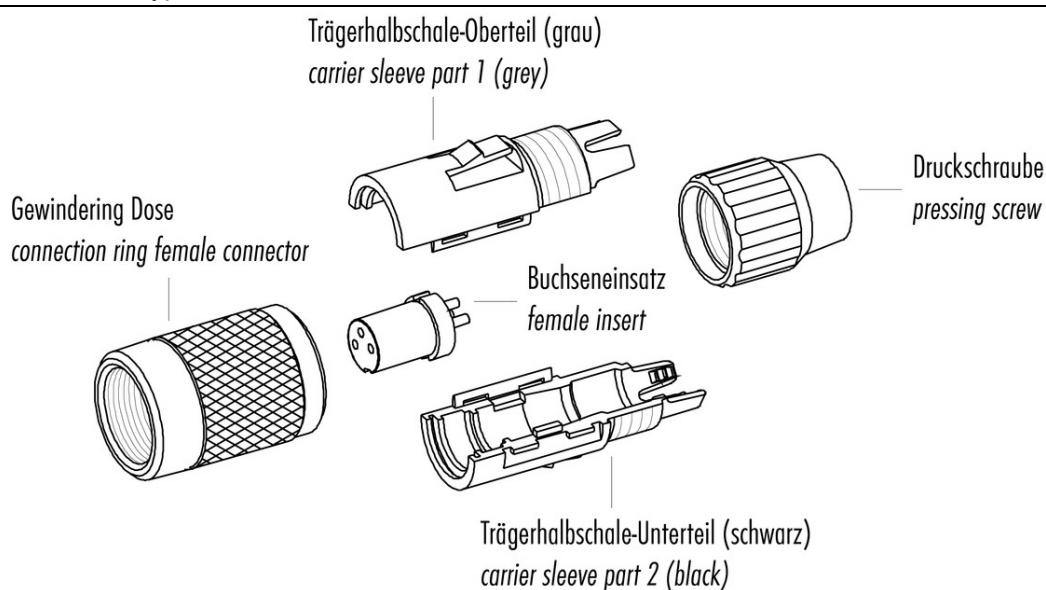

Achtung: max. Drehmoment des Gewinderinges im Flanschsteckverbinder: 50cNm (handfest)
Attention: max. torque of ring nut in socket connector: 50cNm (manual adjustment)

Attention:

For long cable connections, the voltage drop on the cable must be taken into account so that the required supply voltage is applied to the weather station.

Calculation of the voltage drop on the cable. $U_{Ltg} = R_L * I$; $R = 2 * l * \rho / A$; ρ (rho) = 0.018

Example: $I = 0.3A$, $A = 0.14mm^2$, $L = 100m$

$R = 2 * l * \rho / A$, $R = 25.7\Omega$

$U_{Ltg} = R_L * I$, $U_{Ltg} = 7.7V$

2.3.2 Wiring diagram

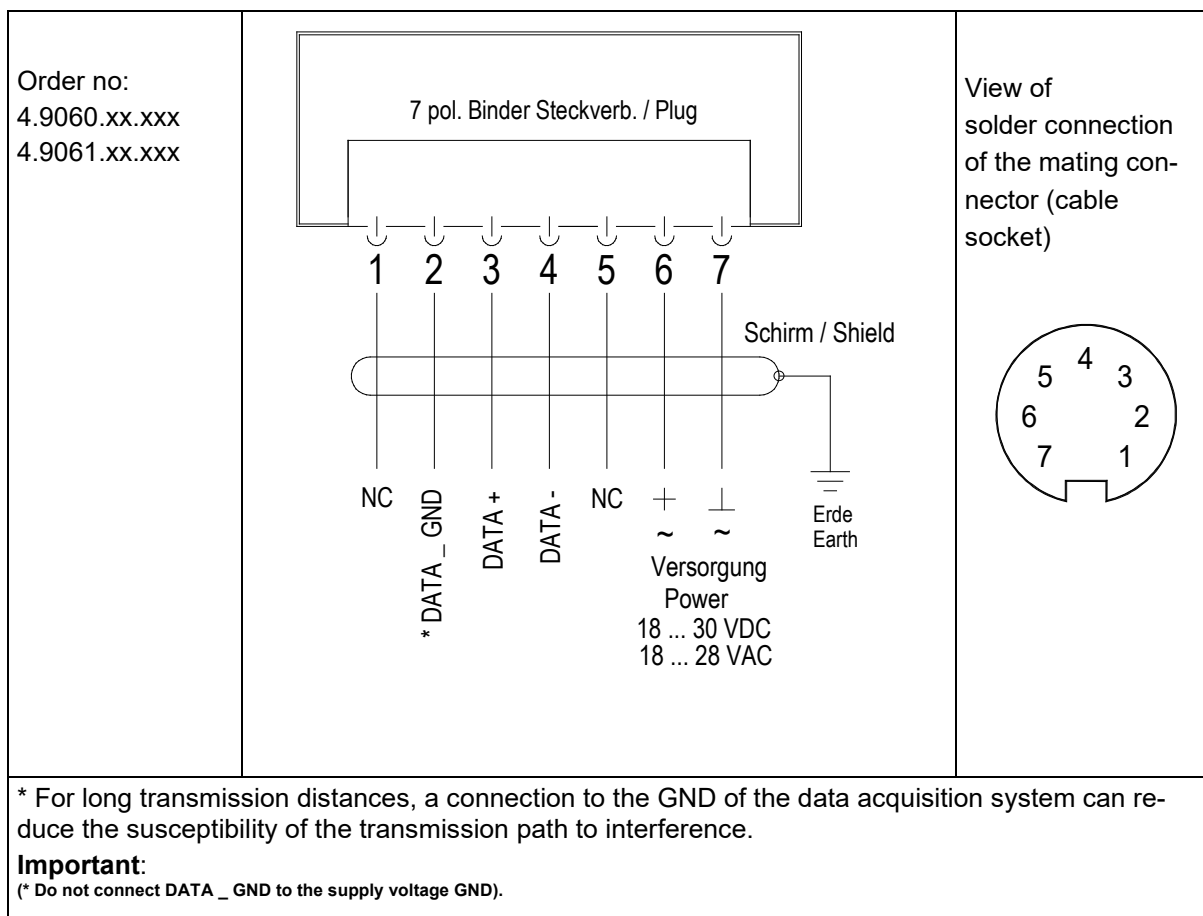

2.3.3 Connection for 5-core cable Article no. 510023 / 510024 / 510197

PIN	Wire color	Function
1		NC
2	WHITE	* DATA _ GND
3	BROWN	DATA +
4	GREEN	DATA -
5		NC
6	YELLOW	+ Supply 18...30VDC / 18...28VAC
7	GRAY	- Supply 18...30VDC / 18...28VAC

* For long transmission distances, a connection to the GND of the data acquisition system can reduce the susceptibility of the transmission path to interference.

Important:
* Do not connect DATA _ GND to the supply voltage GND.

3 Commissioning MQTT / LoRaWAN

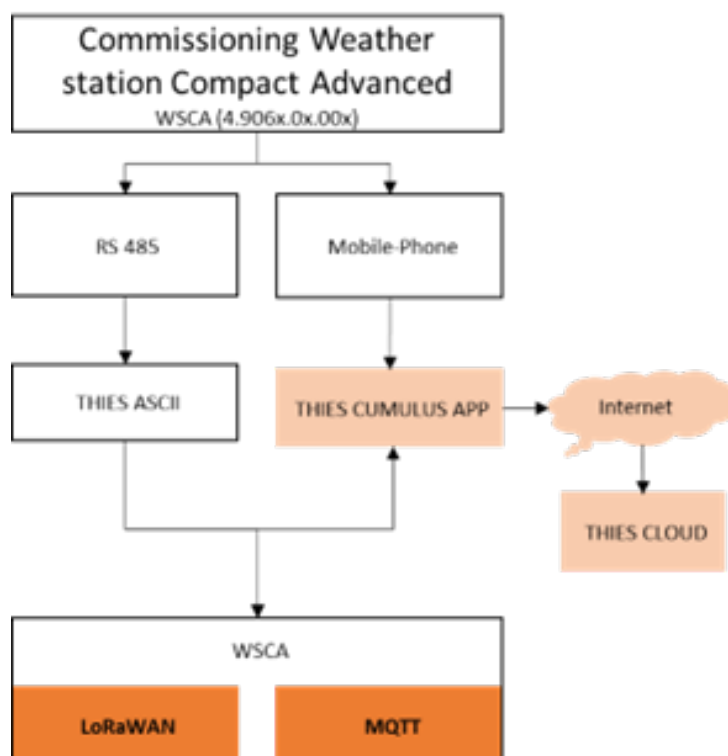

4 Technical data

Wind speed		
	Type	Thermal anemometer rotationally symmetrical
	Measuring range	0 ... 40m/s
	Resolution	0.1m/s
	Accuracy	Up to 10m/s: ±1m/s (RMS average over 360°). From 10m/s: ± 5% (RMS - average over 360°).
Wind direction		
	Type	Thermal anemometer
	Measuring range	1 ... 360°
	Resolution	°
	Accuracy with laminar flow	± 10°
Brightness		
	Type	Silicon sensor
(East, South, West)	Measuring range	0...150kLux
	Resolution	0.1kLux
	Accuracy	±3 % (± 4.5kLux)
	Spectral range	475 ... 650nm

Twilight		
	Type	Silicon sensor
	Measuring range	0...999Lux
	Resolution	1Lux
	Accuracy	±10Lux
Global radiation		
	Type	Silicon sensor
	Measuring range	0 ... 1300W/m ²
	Resolution	1W/m ²
	Accuracy	±10 % (± 130W/m ²)
	Spectral range	350 ... 1100nm
Precipitation		
	Type	Ceramic, capacitance measurement Sensor surface heated
	Precipitation	yes/no
	Hail	yes/no
	Frost	yes/no
	Ice	yes/no
	Snow	yes/no
	Precipitation level	
	1	No to minimal drop (<0.01mm per min)
	2	Light precipitation (0.01...0.04mm per min)
	3	Moderate precipitation (0.04...0.2mm per min)
	4	Heavy precipitation (0.2...0.8mm per min)
	Heating capacity, dry sensor, condensation protection	0,1W
	Heat output, wet sensor Drying phase	1,1W
Temperature		
	Type	PT1000
	Measuring range	-30 ... +60°C
	Resolution	0,1 °C
	Accuracy at wind speeds > 2m/s	±1 °C (-5 ...+25°C)
Air pressure sensor		
	Type	Piezo resistive
	Measuring range	300 ... 1100hPa
	Resolution	0.01hPa
	Accuracy	±0.5hPa @ 20°C
	Long-term stability	±0.1hPa / year
Humidity sensor		
	Type	CMOS capacitive

Relative humidity		
	Measuring range	0 ... 100% rel. humidity
	Resolution	0.1% rel. humidity
	Accuracy at wind speeds > 2m/s	±10% rel. H. @ 20°C
Absolute humidity		
	Measuring range	0 ... 400g/m ³
	Resolution	0.01g/m ³
Dew point temperature		
	Measuring range	-30 ... +60°C
	Resolution	0,1°C
Internal housing temperature		
	Type	Silicon sensor
	Measuring range	-30 ... +60°C
	Resolution	0,1°C
	Accuracy	±2°C
Digital interface		
	Type	RS485
	Operating mode	Half-duplex mode
	Baud rate	1200, 2400, 4800, 9600, 19200, 38400, 57600, 115200
	Data format	ASCII (command interpreter: THIES, 4.9060/1.xx.xx0) Binary (command interpreter: MODBUS RTU, 4.9060/1.xx1)
Wireless WLAN		2.4GHz IEEE 802.11b/g/n
	Transmission power	+16dBm
	Range	Approx. 20m in open field
	Mode	STA + SoftAP (simultaneously: station and access point mode. SoftAP mode switches off 5 minutes after restart)
	Security	WPA2 (WPA and WPA3, Personal and Open are not supported)
	Cloud	Send data to MQTT broker
LoRaWAN		
EU market (4.9061.01.xxx)	Frequency band	EU868
	Transmission frequency	868MHz
	Transmission power	+14dBm (adjustable)
	Modulation	LoRa
	Protocol	LoRaWAN v1.0.2 Class C
US market	Frequency band	915MHz

(4.9061.11.xxx)		
	Transmission power	+18.5dBm (adjustable)
	Modulation	LoRa
	Protocol	LoRaWAN v1.0.2 Class C
General		
	Operating voltage	18 ... 30VDC, 18 ... 28VAC
	Power consumption	200mA @ 24V (max. 0,8A AC, max. 0,5A DC)
	Ambient condition	Temperature range
		-30 ... +60°C
		Humidity range
		Non-condensing
To avoid false-positive LV outputs, the HP=20 setting is recommended for use in hot and humid climates (RF>85% @ air temperature>35°C).		
GPS reception	GPS receiver with low power consumption, integrated RTC and antenna	Frequency: 1,575.42 ... 1,602MHz
	Service life of the RTC (without supply voltage)	Approx. 3 days
Housing		
	Material	PC
	Dimensions	See dimensional drawing
	Weight	0,22kg
	Protection class	IP65 in operating position
	Connection type	7-pin plug

Table1 : Technical data

5 Input circuitry

The sensor is equipped with a half-wave rectification at the input. This means that PIN 2 (DATA_GND) and PIN 7 (-supply) have the same potential, but are decoupled via a resistor.

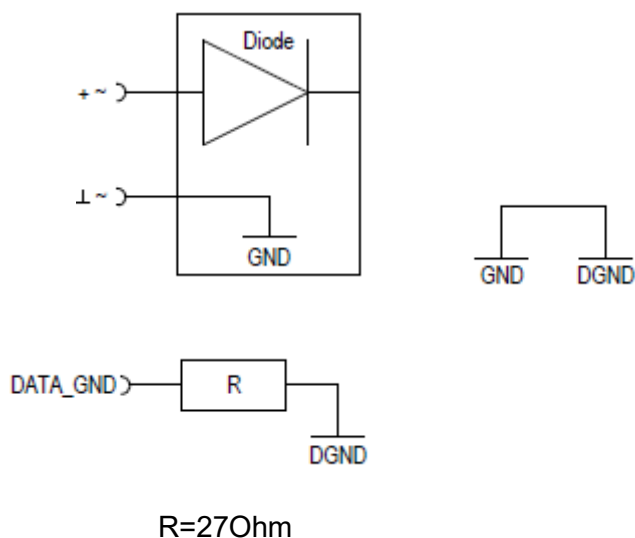

6 Dimensional drawing [in mm]

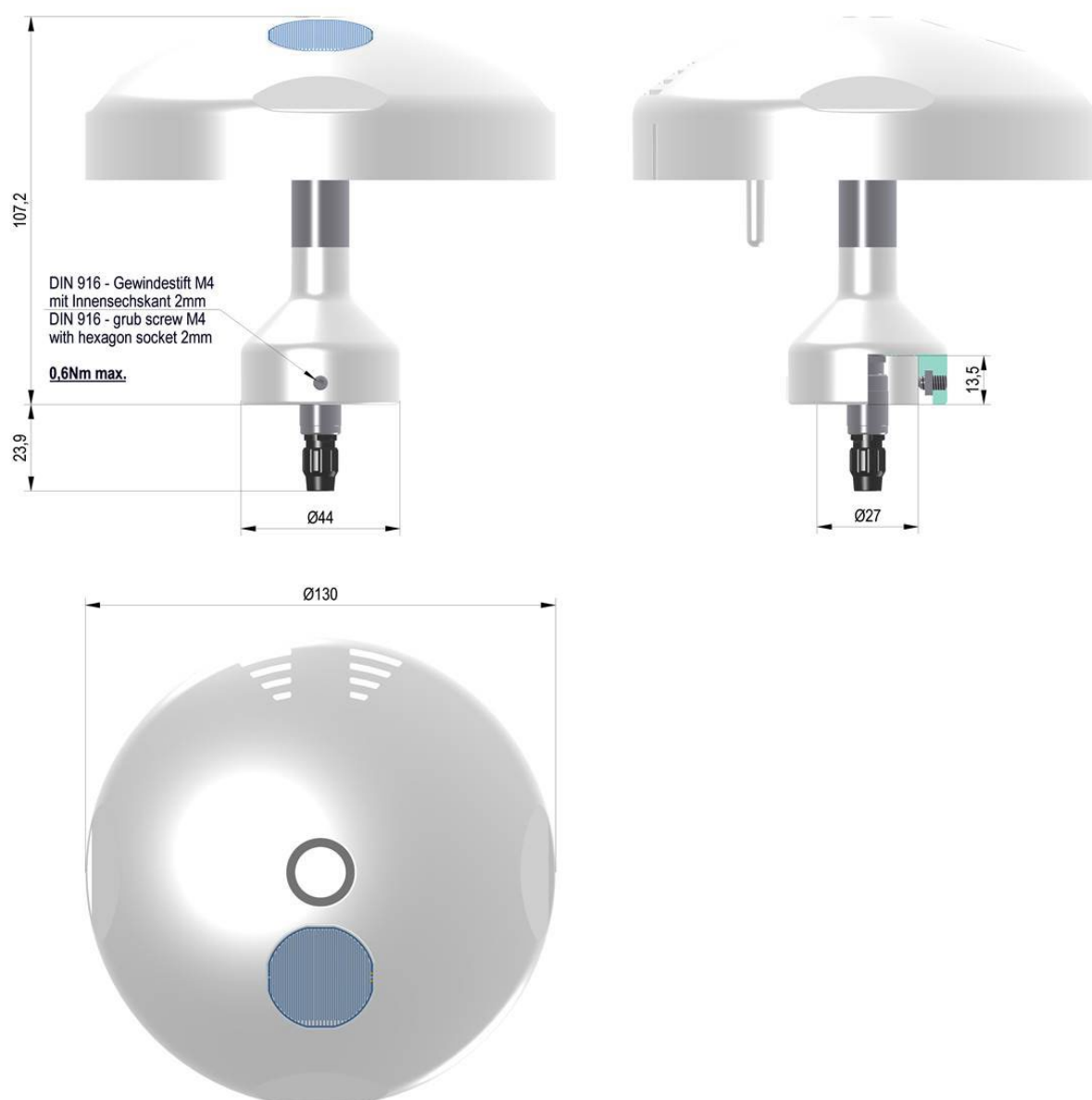

7 Further information / documents for download

Further information can be found in the operating instructions. This document and the short operating instructions are available for download at the following link.

Short operating instructions:

https://www.thiesclima.com/en/db/dnl/4.906x.00.x0x_wsca_eng_short.pdf

Operating instructions:

https://www.thiesclima.com/en/db/dnl/4.906x.00.x0x_wsca_eng.pdf

8 EC Declaration of Conformity

Manufacturer: Adolf Thies GmbH & Co. KG
 Hauptstraße 76
 37083 Göttingen, Germany
<http://www.thiesclima.com>

Product: Weather Station Compact Advanced (WSCA)

Doc. Nr. 2024-45791_CE

Article Overview:

4.9060.01.000 4.9060.01.001 4.9061.01.000 4.9061.11.000 4.9061.01.001 4.9061.11.001

The indicated products correspond to the essential requirement of the following European Directives and Regulations:

2014/30/EU	26.02.2014	DIRECTIVE 2014/30/EU OF THE EUROPEAN PARLIAMENT AND OF THE COUNCIL of 26 February 2014 on the harmonisation of the laws of the Member States relating to electromagnetic compatibility.
2014/35/EU	26.02.2014	DIRECTIVE 2014/35/EU OF THE EUROPEAN PARLIAMENT AND OF THE COUNCIL of 26 February 2014 on the harmonisation of the laws of the Member States relating to the making available on the market of electrical equipment designed for use within certain voltage limits.
2014/53/EU	16.04.2014	DIRECTIVE 2014/53/EU of the European Parliament and of the Council of 16 April 2014 on the harmonisation of the laws of the Member States relating to the making available on the market of radio equipment and repealing Directive 1999/5/EC Text.
2011/65/EU + 2015/863/EU + 2017/2102/EU	03.01.2013 31.03.2015 15.11.2017	DIRECTIVE (EU) 2011/65/EU + 2015/863/EU + 2017/2102, of the European Parliament and of the Council on the restriction of the use of certain hazardous substances in electrical and electronic equipment.
2012/19/EU	13.08.2012	DIRECTIVE 2012/19/EU OF THE EUROPEAN PARLIAMENT AND OF THE COUNCIL of 4 July 2012 on waste electrical and electronic equipment (WEEE).

The indicated products comply with the regulations of the directives. This is proved by the compliance with the following standards:

EN 301489-1 V 2.2.3	2019-11	ElectroMagnetic Compatibility (EMC) standard for radio equipment and services; Part 1: Common technical requirements; Harmonised Standard for ElectroMagnetic Compatibility
EN 301489-3 V 2.3.2	2023-01	ElectroMagnetic Compatibility (EMC) standard for radio equipment and services; Part 3: Specific conditions for Short-Range Devices (SRD) operating on frequencies between 9 kHz and 246 GHz; Harmonised Standard covering the essential requirements of article 3.1(b) of Directive 2014/53/EU
EN 303413 V1.1.1	2017-06	Satellite Earth Stations and Systems (SES); Global Navigation Satellite System (GNSS) receivers; Radio equipment operating in the 1 164 MHz to 1 300 MHz and 1 559 MHz to 1 610 MHz frequency bands; Harmonised Standard covering the essential requirements of article 3.2 of Directive 2014/53/EU
EN 301489-17 V 3.2.4	2020-09	ElectroMagnetic Compatibility (EMC) standard for radio equipment and services - Part 17: Specific conditions for Broadband Data Transmission Systems - Harmonised Standard for ElectroMagnetic Compatibility (Endorsement of the English version EN 301 489-17 V3.2.4 (2020-09) as a German standard)
EN 301489-19 V2.2.1	2022-09	ElectroMagnetic Compatibility (EMC) standard for radio equipment and services - Part 19: Specific conditions for Receive Only Mobile Earth Stations (ROMES) operating in the 1,5 GHz band providing data communications and GNSS receivers operating in the RNSS band (ROGNSS) providing positioning, navigation and timing data - Harmonised Standard covering the essential requirements of article 3.1(b) of Directive 2014/53/EU (Endorsement of the English version EN 301 489-19 V2.1.1 (2019-04) as a German standard)
DIN EN 55016-2-3	2020-11	Specification for radio disturbance and immunity measuring apparatus and methods - Part 2-3: Methods of measurement of disturbances and immunity - Radiated disturbance measurements (CISPR 16-2-3:2016 + A1:2019); German version EN 55016-2-3:2017 + A1:2019
DIN EN 55016-2-1	2019-11	Specification for radio disturbance and immunity measuring apparatus and methods - Part 2-1: Methods of measurement of disturbances and immunity - Conducted disturbance measurements (CISPR 16-2-1:2014 + A1:2017); German version EN 55016-2-1:2014 + A1:2017
DIN EN 55032+55032/A11	2021-03	Electromagnetic compatibility of multimedia equipment - Emission Requirements (CISPR 32:2015)
DIN EN 61000-4-2	2009-12	Electromagnetic Compatibility (EMC) - Part 4-2: Testing and measuring procedures - Testing of immunity to static electricity discharge
DIN EN 61000-4-5	2019-03	Electromagnetic compatibility (EMC) - Part 4-5: Test and measurement procedures - Testing of immunity to surge voltages
DIN EN 61000-4-6	2014-08	Electromagnetic compatibility (EMC) - Part 4-6: Test and measurement methods - Immunity to conducted disturbances, induced by high-frequency fields
DIN IEC 61000-6-2	2019-11	Electromagnetic compatibility Immunity for industrial environment
DIN EN 61000-6-3:2007 + A1:2011+2012-11+2022+06	2011-09	Electromagnetic compatibility (EMC). Generic standards. Emission standard for residential, commercial and light-industrial environments
DIN IEC 62368-1	2016-04	Audio/video, information and communication technology equipment - Part 1: Safety requirements (IEC 62368-1:2014)
DIN IEC 63000	2019-05	Technical documentation for the assessment of electrical and electronic products with respect to the restriction of hazardous substances.

Göttingen, 14.05.2025



General Manager - Dr. Christoph Peper



Development Manager - ppa. Jörg Peterreit

This declaration of conformity is issued under the sole responsibility of the manufacturer.

This declaration certifies the compliance with the mentioned directives, however does not include any warranty of characteristics.

Please pay attention to the security advises of the provided instructions for use.

9 UK-CA-Declaration of Conformity

Manufacturer: Adolf Thies GmbH & Co. KG
 Hauptstraße 76
 37083 Göttingen, Germany
<http://www.thiesclima.com>

Product: Weather Station Compact Advanced (WSCA)

Doc. Nr. 2024-45791_CA

Article Overview:

4.9060.01.000 4.9060.01.001 4.9061.01.000 4.9061.11.000 4.9061.01.001 4.9061.11.001

The indicated products correspond to the essential requirement of the following Directives and Regulations:

1091	08.12.2016	The Electromagnetic Compatibility Regulations 2016
1101	08.12.2016	The Electrical Equipment (Safety) Regulations 2016
1206	26.12.2017	The Radio Equipment Regulations 2017
2011/65/EU + 2015/863/EU + 2017/2102/EU	03.01.2013 31.03.2015 15.11.2017	DIRECTIVE (EU) 2011/65/EU + 2015/863/EU + 2017/2102, of the European Parliament and of the Council on the restriction of the use of certain hazardous substances in electrical and electronic equipment.
3113	01.01.2021	Regulations: waste electrical and electronic equipment (WEEE)

The indicated products comply with the regulations of the directives. This is proved by the compliance with the following standards:

EN 300 400 V 2.2.1	2017-03	Short Range Devices (SRD); Radio equipment to be used in the 1 GHz to 40 GHz frequency range; Harmonised Standard for access to radio spectrum
EN 301489-3 V 2.3.2	2023-01	ElectroMagnetic Compatibility (EMC) standard for radio equipment and services; Part 3: Specific conditions for Short-Range Devices (SRD) operating on frequencies between 9 kHz and 246 GHz; Harmonised Standard covering the essential requirements of article 3.1(b) of Directive 2014/53/EU
EN 303 413 V1.1.1	2017-06	Satellite Earth Stations and Systems (SES); Global Navigation Satellite System (GNSS) receivers; Radio equipment operating in the 1 164 MHz to 1 300 MHz and 1 559 MHz to 1 610 MHz frequency bands; Harmonised Standard covering the essential requirements of article 3.2 of Directive 2014/53/EU
EN 301489-17 V 3.2.4	2020-09	ElectroMagnetic Compatibility (EMC) standard for radio equipment and services - Part 17: Specific conditions for Broadband Data Transmission Systems - Harmonised Standard for ElectroMagnetic Compatibility (Endorsement of the English version EN 301 489-17 V3.2.4 (2020-09) as a German standard)
EN 301489-19 V2.2.1	2022-09	ElectroMagnetic Compatibility (EMC) standard for radio equipment and services - Part 19: Specific conditions for Receive Only Mobile Earth Stations (ROMES) operating in the 1,5 GHz band providing data communications and GNSS receivers operating in the RNSS band (ROGNSS) providing positioning, navigation and timing data - Harmonised Standard covering the essential requirements of article 3.1(b) of Directive 2014/53/EU (Endorsement of the English version EN 301 489-19 V2.1.1 (2019-04) as a German standard)
BS EN 55016-2-3+A2:2018-01-31	31.01.2018	Specification for radio disturbance and immunity measuring apparatus and methods. Methods of measurement of disturbances and immunity. Radiated disturbance measurements
BS EN 55016-2-1+A1:2014-07-31	31.07.2014	Specification for radio disturbance and immunity measuring apparatus and methods. Methods of measurement of disturbances and immunity. Conducted disturbance measurements
DIN EN 55032+55032/A11	2021-03	Electromagnetic compatibility of multimedia equipment. Emission Requirements
BS EN 61000-4-2	31.05.2009	Electromagnetic compatibility (EMC). Testing and measurement techniques. Electrostatic discharge immunity test
BS EN 61000-4-5+A1	30.09.2014	Electromagnetic compatibility (EMC). Testing and measurement techniques. Surge immunity test
BS EN 61000-4-6	28.02.2014	Electromagnetic compatibility (EMC). Testing and measurement techniques. Immunity to conducted disturbances, induced by radio-frequency fields
BS EN IEC 61000-6-2	25.02.2019	Electromagnetic compatibility (EMC). Generic standards. Immunity standard for industrial environments
BS EN IEC 61000-6-3	30.03.2021	Electromagnetic compatibility (EMC). Generic standards. Emission standard for equipment in residential environments
BS EN IEC 62368-1	2016-04	Audio/video, information and communication technology equipment. Safety requirements
BS EN IEC 63000	10.12.2018	Technical documentation for the assessment of electrical and electronic products with respect to the restriction of hazardous substances

Göttingen, 14.05.2025

Legally binding signature:



General Manager - Dr. Christoph Peper

Legally binding signature:



Development Manager - ppa. Jörg Peterit

This declaration of conformity is issued under the sole responsibility of the manufacturer.

This declaration certifies the compliance with the mentioned directives, however does not include any warranty of characteristics.

Please pay attention to the security advises of the provided instructions for use.

**Talk to us about your system requirements.
We will be happy to advise you.**

ADOLF THIES GMBH & CO. KG

Meteorology and environmental measurement technology
Hauptstraße 76 - 37083 Göttingen - Germany
Phone +49 551 79001-0 - Fax +49 551 79001-65
info@thiesclima.com

www.thiesclima.com

